



SUITE RANGE

INSTRUCTION MANUAL

CLIFTON **1000** Floor-Based
CLIFTON **1000** Wall-Mounted
ELMDON **850** Floor-Based
ELMDON **850** Wall-Mounted
SHENSTONE **1250**
HANBURY **850**



CONTENTS

EU Directives and UKCA Standards.....	3
Important information and Health & Safety.....	4
Attaching the woodwork.....	5
Wall-mounted installation.....	8
Riser installation	12
Model dimensions	13
Front and side glass installation	14
Remote operation	16
Warranty	18

The following materials and components should be disposed of in accordance with the below table.

Metal - Steel or cast iron	Can be taken to a local recycling centre for reuse to reduce waste going to landfill.
Glass & Screens	Can be taken to a local recycling centre for reuse to reduce waste going to landfill.
Vermiculite	Non hazardous material. Vermiculite can be crushed up and used for plant bedding and ash used for composting or disposed of at a local recycling centre for reuse to reduce waste going to landfill.
Electrical components - Fans, heater elements, PCB's, Power pack's, LED's	Dispose at a local recycling centre In accordance with latest WEEE directive.
Log fuel effects	These logs contain refractory ceramic fibre materials which requires disposal in accordance with WEEE legislation.
Natural Wood	Can be taken to a local recycling centre for reuse to reduce waste going to landfill.

EU DIRECTIVES

All Aura Fires products meet the requirements of the EC Directives. These directives have been met by compliance with the following standards:

EU 2011-65/EU 2015/863 Restriction of Hazardous Substances.

References to the relevant designated standards used:

EN 55014-1:2006 + A1:2009 + A2:2011 Electromagnetic Compatibility.

EN 55014-2:2015 Electromagnetic Compatibility.

EN 61000-3-2:2014 Electromagnetic Compatibility (EMC). Limits. Limits for Harmonic Current Emissions.

EN 61000-3-3:2013 Electromagnetic Compatibility (EMC). Limits. Limitation of Voltage Changes, Voltage Fluctuations and Flicker.

EN 60335-1:2012 + A11:2014 Household and similar electrical appliances - Safety

EN 60335-2-30:2009+A11:2012 Household and similar electrical appliances. Safety. Particular requirements for room heaters

UKCA STANDARDS

All Aura Fires products are in conformity with the relevant UK Statutory Instruments (and their amendments).

2016 No. 1101 The Electrical Equipment (Safety) Regulations 2016

2016 No. 1091 The Electromagnetic Compatibility Regulations 2016

2012 No. 3032 The Restriction Of Use Of Certain Hazardous Substances In Electrical And Electronic Equipment Regulations 2012



IMPORTANT INFORMATION AND HEALTH & SAFETY

When using electrical appliances, basic precautions should always be followed to reduce the risk of fire, electric shock, and injury to persons, including the following:

- Read all of the instructions carefully before using the appliance, only use this appliance as described in this manual. Any other use not recommended by the manufacturer may cause injury to persons, or damage to the appliance.
- Remove all packaging and dispose of it at an appropriate recycling facility.
- When transporting or storing the appliance and power lead, keep in a dry place, away from excessive vibration and store so as to avoid damage.
- This fireplace is hot when in use. To avoid burns, do not let bare skin touch hot surfaces. The trim around the heater outlet becomes hot during heater operation. DANGER: High temperatures may be generated under certain abnormal conditions.
- Do not install this appliance immediately in front of a fixed socket outlet.
- Do not install this appliance in the immediate surroundings of a bath, shower, swimming pool or any other area where the appliance could come into contact with water or humidity, e.g. a bathroom.
- Do not use in areas where gasoline, paint, or any flammable liquids are used or stored.
- This appliance is only suitable for indoor use, do not use outdoors.
- Do not cover the appliance, or let the air inlet/outlet to be obstructed in any way as it may overheat.
- Keep the power lead away from hot surfaces and the heater outlet. Do not route the power lead in front of the appliance, or under any carpets or rugs. Do not allow the power lead to be coiled up once installed, as this can cause overheating.
- This appliance must be firmly fixed to or recessed into, a flat internal wall.
- A maintenance hatch must be installed into the surrounding installation to allow future access.
- Always use a certified electrician should new circuits or outlets be required. And always use properly grounded, fused and polarised outlets.
- Where the power lead passes through any masonry wall, stone surround etc. ensure that suitable rubber bushes are fitted at any possible wear points.
- If the power lead is damaged do not use the appliance until it has been replaced.
- Do not use any external switching device, timers, or extension leads. Do not connect the appliance to a circuit that is frequently switched on and off by the utility.
- In the event of a malfunction, switch off the appliance, and disconnect it from the mains power supply. Have the appliance inspected by a certified electrician before reusing.
- Do not use the appliance if it is damaged. In the event of any damage to the appliance, please contact the retailer from whom the appliance was purchased.
- Any repairs must only be performed by a certified electrician.
- Extreme caution is necessary when any heater is used by, located near children or people of reduced mobility, and whenever the unit is left operating and unattended.
- Young children should be supervised to ensure that they do not play with the appliance.
- Disconnect from the power supply before performing any cleaning, maintenance or relocation of the unit. Do not use steam cleaners, or aerosols near the appliance.
- Do not burn wood or anything else in this appliance.
- Do not strike the glass. The glass used is toughened safety glass, if broken it will shatter into small chunks which are less likely to cause injury.
- Do not drill or screw any new holes into the appliance.

ATTACHING THE WOODWORK

All the suite models that we ship either have the woodwork already attached, or on larger models the woodwork will be packed separately from the fire and require attaching by the installer or customer. Detailed below you will see information on how your suite should arrive to you. We supply wall mounting brackets and mirror (180°) brackets with all of our suites.

If your woodwork arrives separately, then follow the step-by-step guide on how to attach. If your woodwork has already been attached, then you can continue to the wall-mounting or riser installation section.

MODEL	WOODWORK ATTACHED	WOODWORK SEPARATE	180° BRACKET SUPPLIED
Clifton 1000 FS	✗	✓	✓
Clifton 1000	✗	✓	✓
Elmdon 850 FS	✗	✓	✓
Elmdon 850	✗	✓	✓
Hanbury 800 FS	✗	✓	✓
Shenstone 1250 FS	✗	✓	✓

ATTACHING THE WOODWORK

1

On the bottom woodwork section of the suite, unscrew and turn the mirror brackets on the rear 180°, so they are pointing upwards. Then on the top woodwork section, unscrew and turn the mirror brackets 180° so they are pointing downwards.



Bottom woodwork brackets



Top woodwork brackets



2

The fire will have come with 2 bottom brackets already attached, and you can now slide your bottom woodwork section onto these brackets. The top woodwork section sits on top of the fireplace itself and rests on the plaster kit, and the bottom woodwork section will fit in just below the plaster kit.

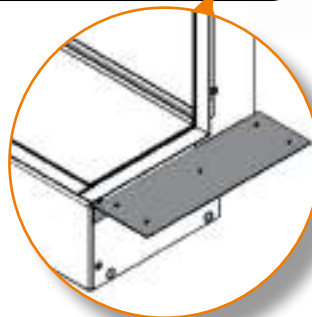
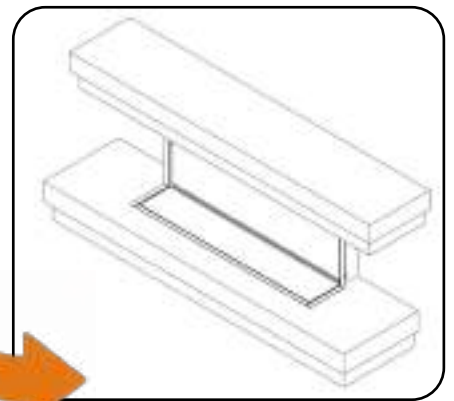
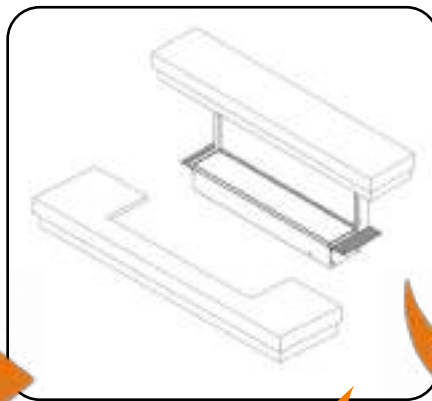
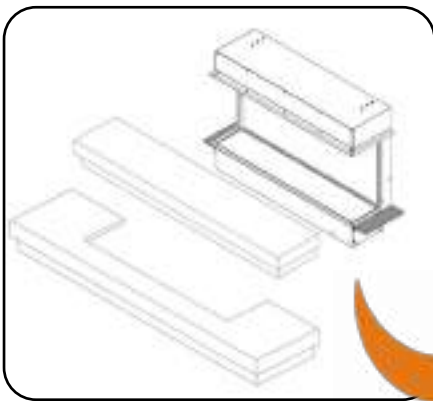

ATTACHING THE WOODWORK

3

Once the appliance has been hung onto the wall bracket (Page 10), you can secure your woodwork in place by screwing through the mirror brackets into the wall using the appropriate fixings. There will be 4 woodwork brackets that need attaching. These will be hidden once you attach your side wings.

PLEASE NOTE: The mirror brackets are to provide extra support for the woodwork only. The weight of the product must be taken by the wall bracket on wall-mounted models, or by the riser on floor-based units.

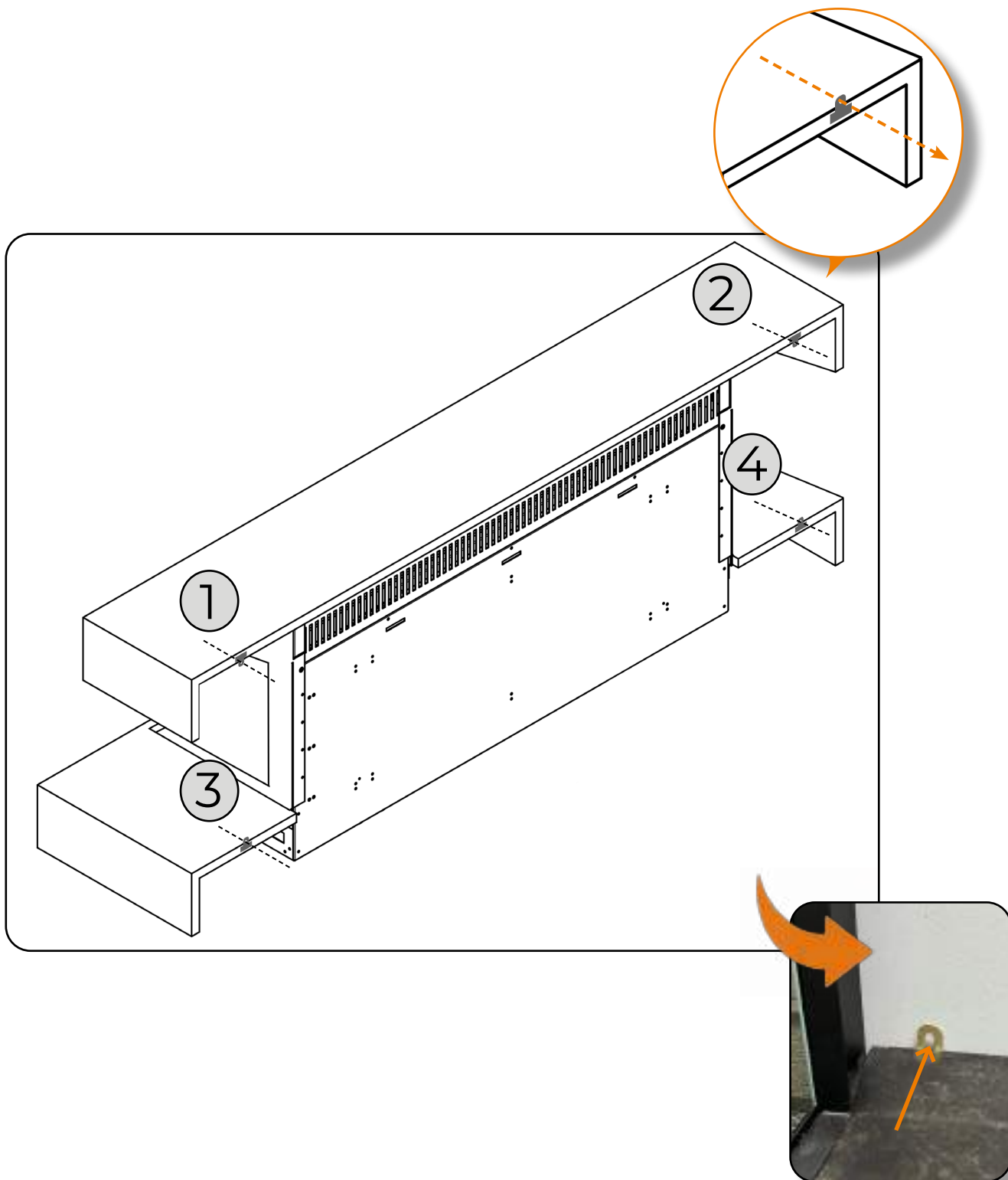

WALL-MOUNTED INSTALLATION

INSTALLATION REQUIREMENTS

Before installing the appliance please read and take into account the following important requirements;

- The appliance must never be installed in front of an electrical socket.
- The appliance must not be installed anywhere that it may come into contact with water, i.e. a bathroom.
- The minimum height above the finished floor level is 300mm.

CHECKS BEFORE INSTALLATION

We recommend turning on the appliance before installation, connect the appliance to a power source using the provided electrical lead, and depress the right side of the rocker switch.

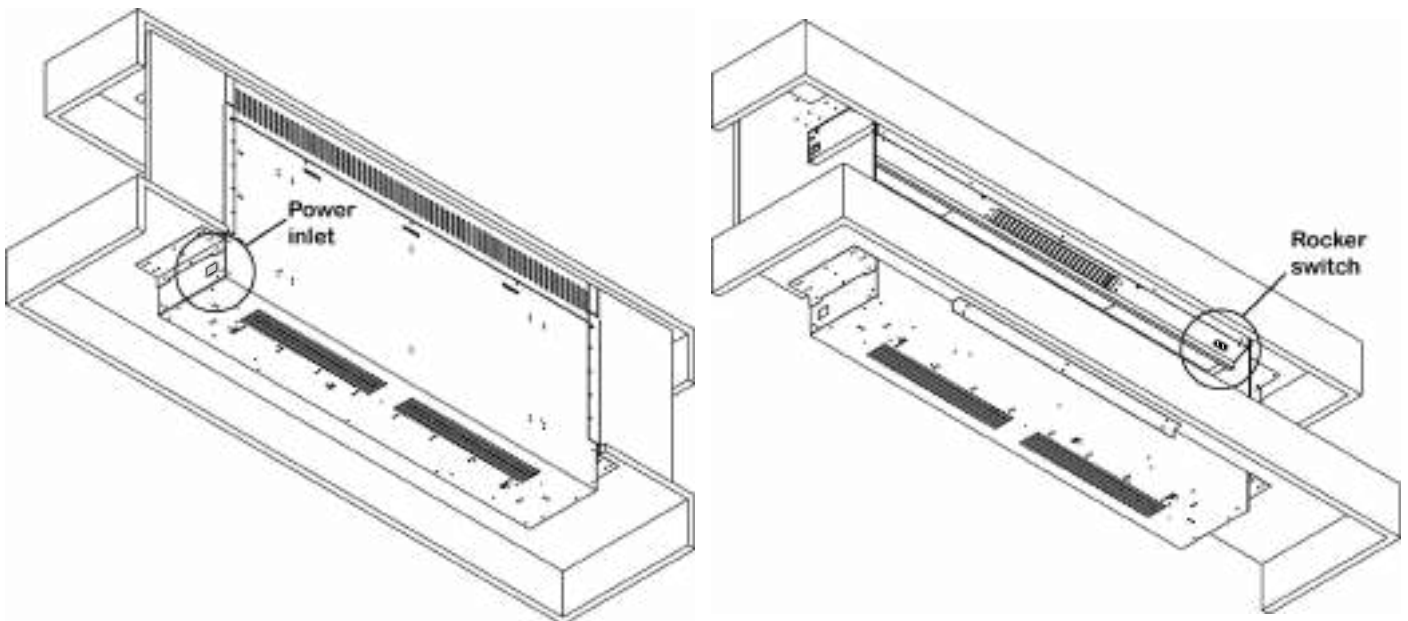

TOOLS REQUIRED

- Tape Measure
- Pencil
- Spirit Level
- Screwdriver
- PZ2 Screw Bit
- Drill Bit
- Wall Plugs (Masonry type supplied)
- Wall Screws (Masonry type supplied)
- Stud Detector (For plasterboard installations only)
- Wall Anchors (For plasterboard installations only. Not supplied)

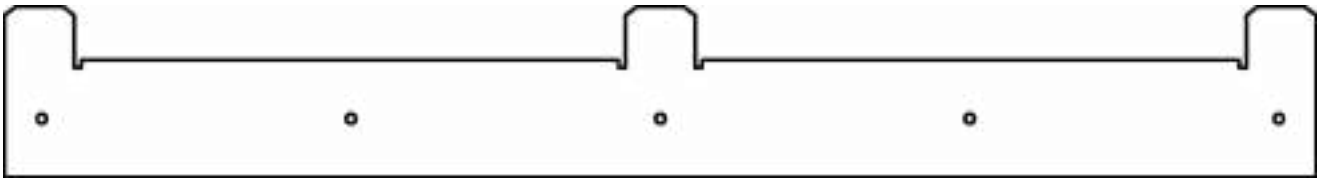

The appliance is supplied with a wall bracket, shown above.

INSTALLATION STEPS

1

Remove the two bottom mounted transit brackets, you won't need these for installation. Then screw on the IEC Clip to the bottom back of the case, with the two provided screws.

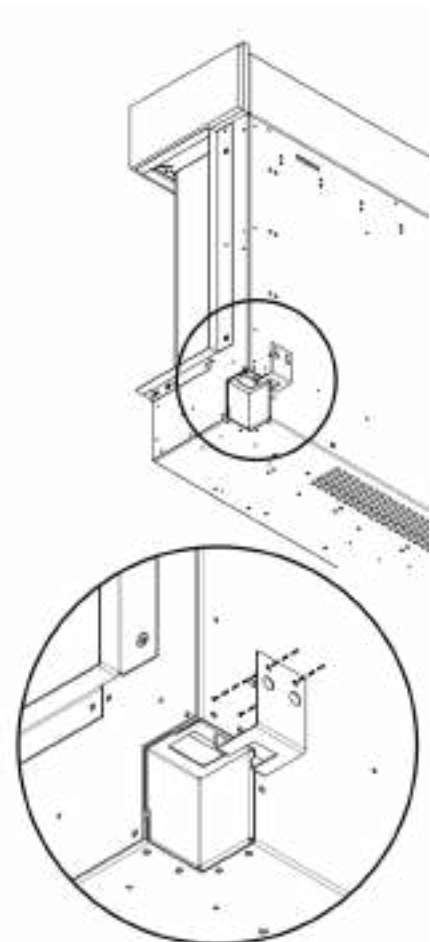
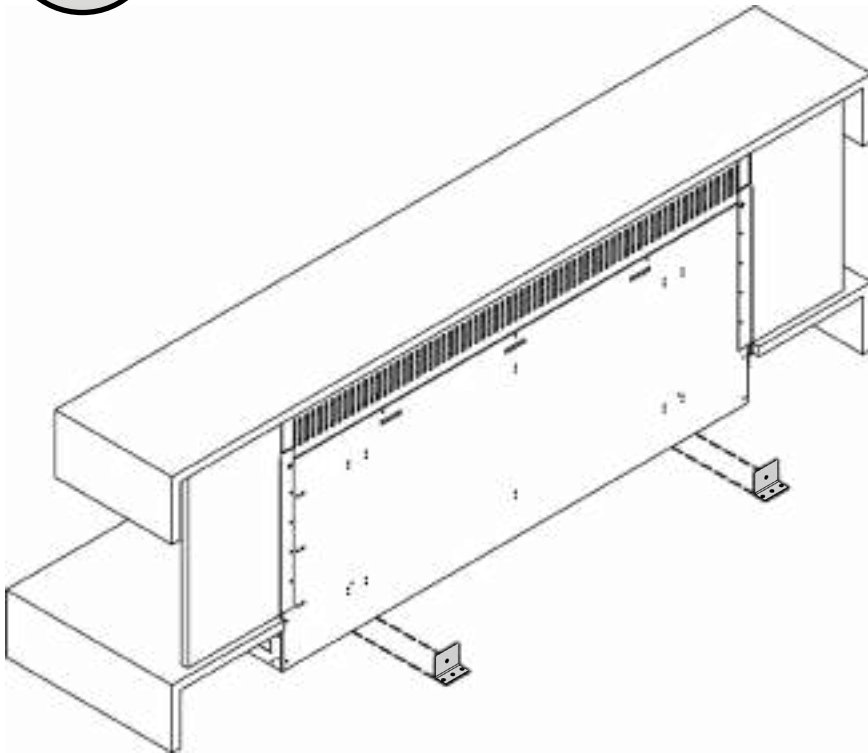

2

Determine the finished height and position that you want the appliance to be located. Then secure the wall bracket to the wall in the position you need using the wall plugs and screws provided. If you're not securing the appliance to a masonry wall you will need to use the appropriate fixings.

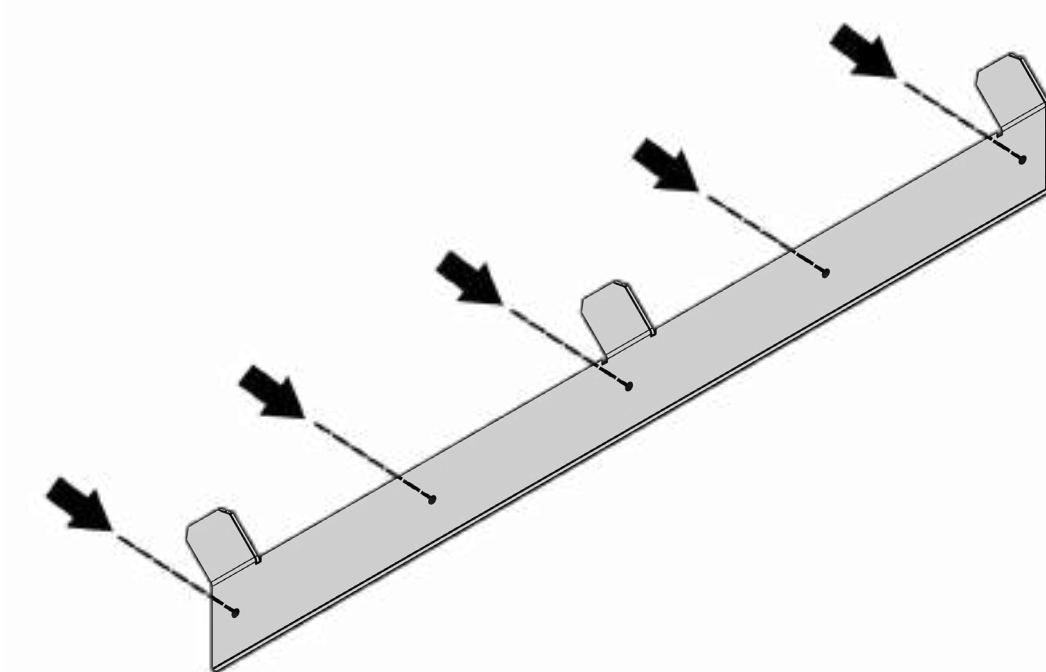

3

You can now hang the appliance on the wall by slotting the tabs of the wall bracket into the slots on the back of the appliance. Connect the appliance to the mains power supply and it is ready to use.

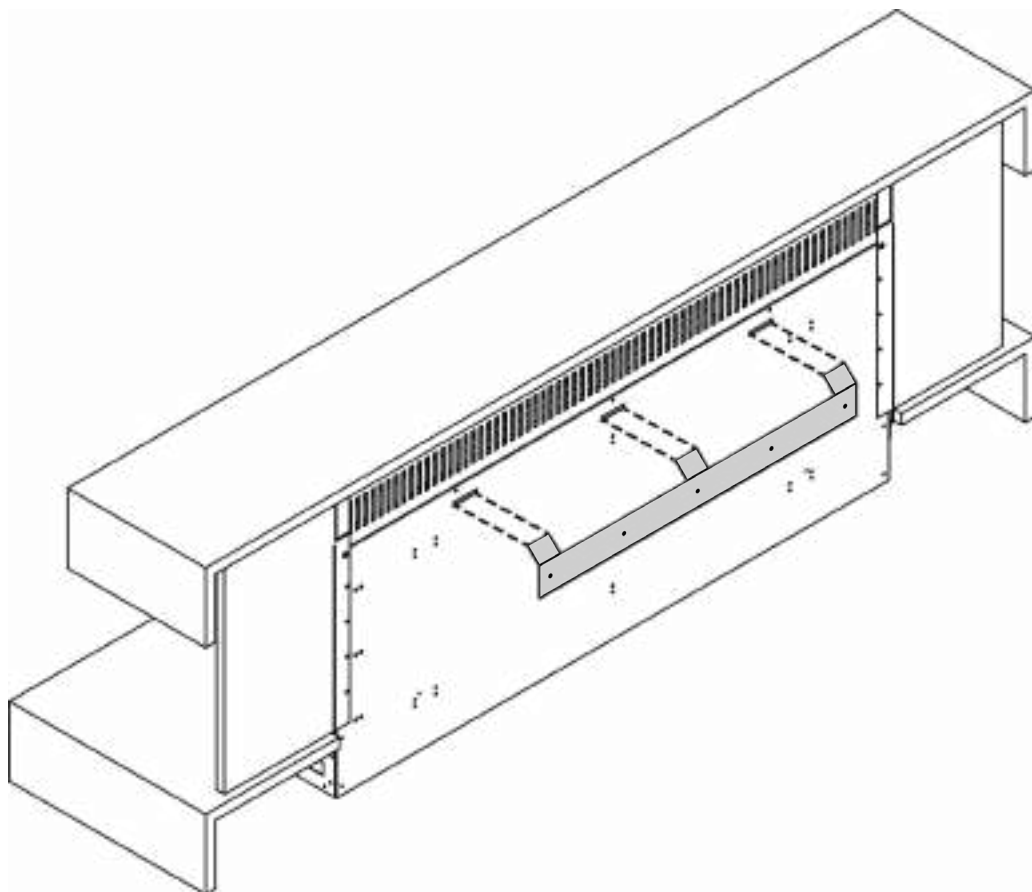

4

Once the appliance has been hung onto the wall bracket, you can secure your woodwork in place by screwing into the wall using the appropriate fixings. There will be 4 woodwork brackets that need attaching.

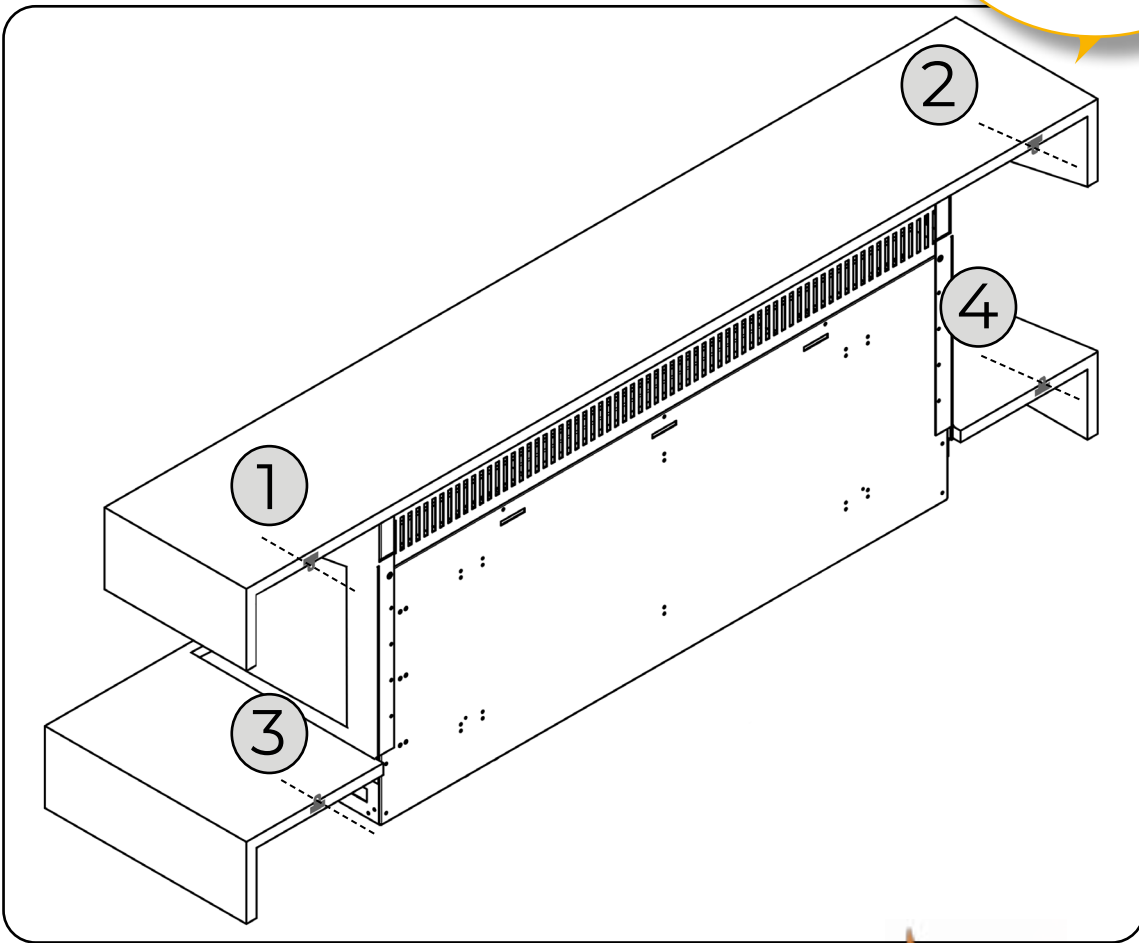
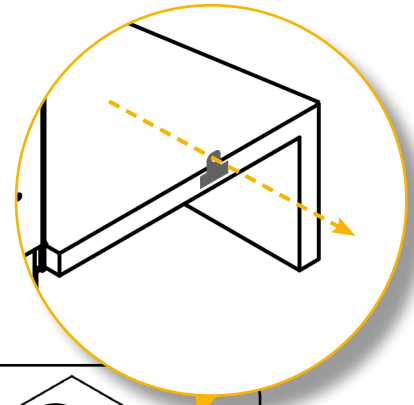

FLOOR-BASED INSTALLATION (WITH RISER)

1

Identify where you want to position your fire in a room. Once you have done this, slide your riser into position. You may want to measure the width of both the suite and the riser so you can identify the centre point of the fireplace.

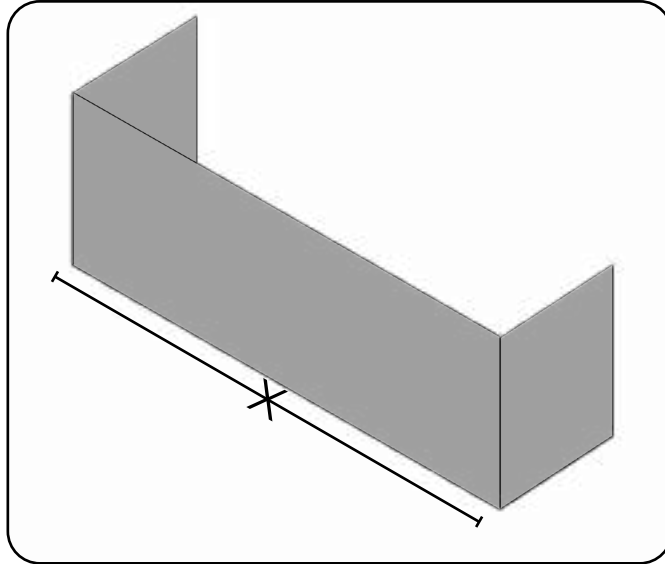

2

Carefully lift your fireplace and insert it into the riser. This will require a minimum of 2 people.

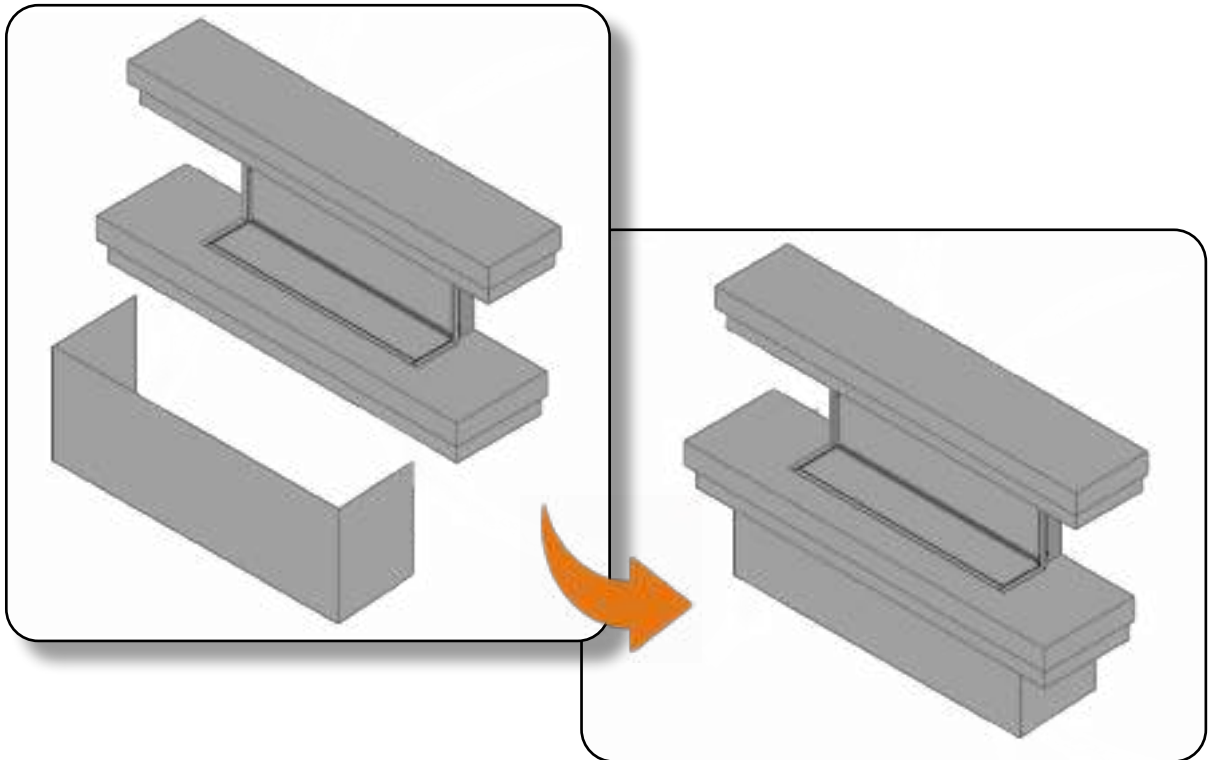

MODEL DIMENSIONS

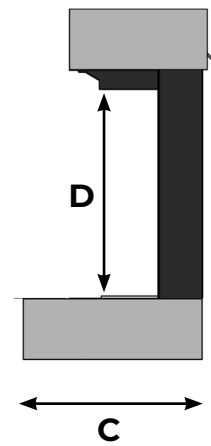
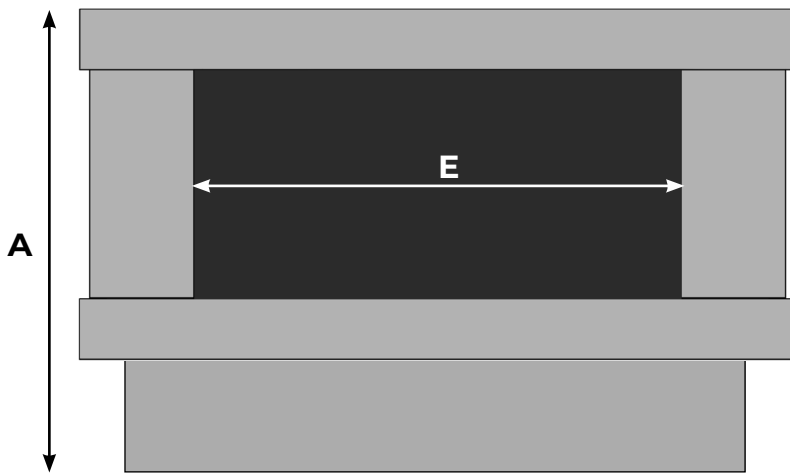
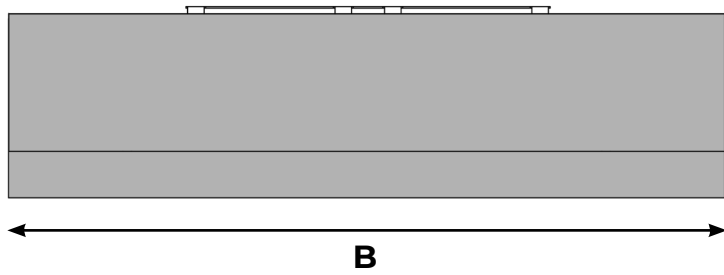

MODEL	A HEIGHT	B WIDTH	C DEPTH	D OPENING HEIGHT	E OPENING WIDTH
Elmdon 850 FB	783mm	1370mm	320mm	414mm	850mm
Elmdon 850 WM	771mm	1370mm	320mm	414mm	850mm
Clifton 1000 FB	734mm	1470mm	310mm	414mm	1000mm
Clifton 1000 WM	530mm	1470mm	310mm	414mm	1000mm
Hanbury 800 FB	940mm	1370mm	460mm	587mm	805mm
Shenstone 1250 FB	865mm	1620mm	405mm	414mm	1255mm

FRONT AND SIDE GLASS INSTALLATION

- 1 Unscrew and remove the top glass retainer panel.

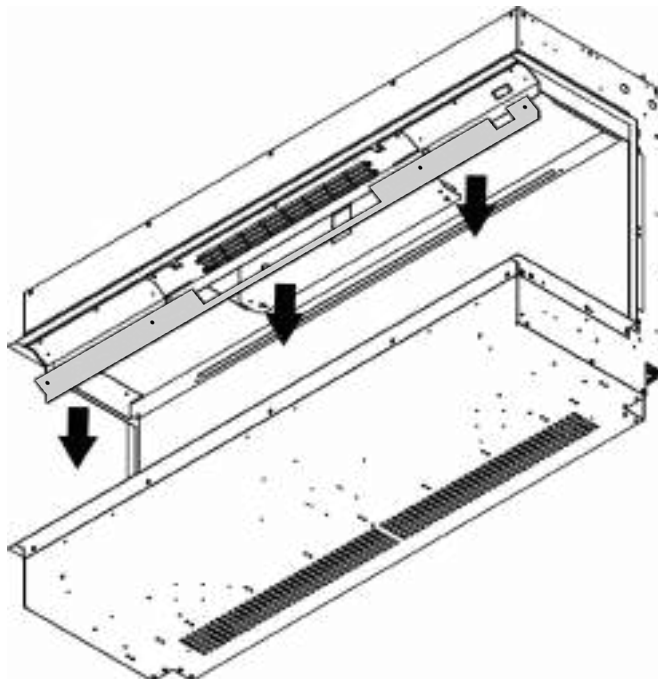

- 2 The side glass can now be slid into the appliance.

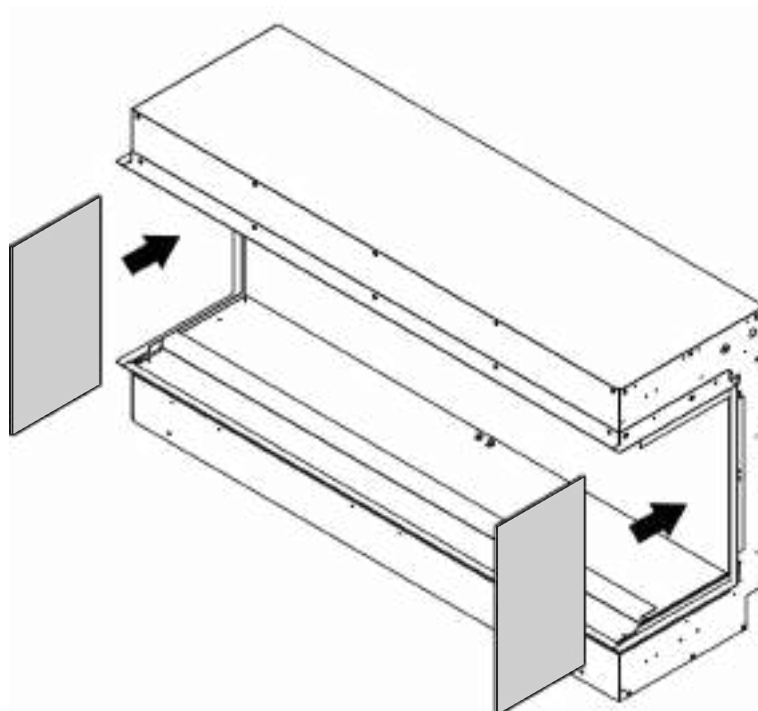

3

Apply the Suction Lifter to the glass and apply the glass to the bottom edge first, then pivot into the appliance.

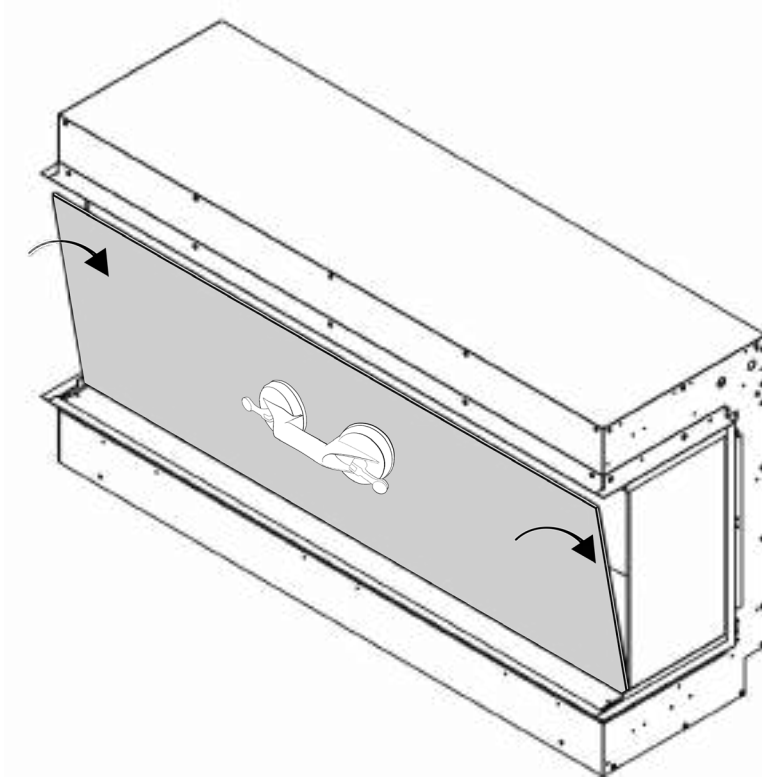

Warning

The Suction Lifter is provided to assist in moving the glass **NEVER** as the sole support of the glass. Always support the glass throughout the entire process until the glass is fully fitted. The glass is toughened safety glass and if broken will shatter into many small chunks.

4

The top glass retainer can now be replaced on the appliance.

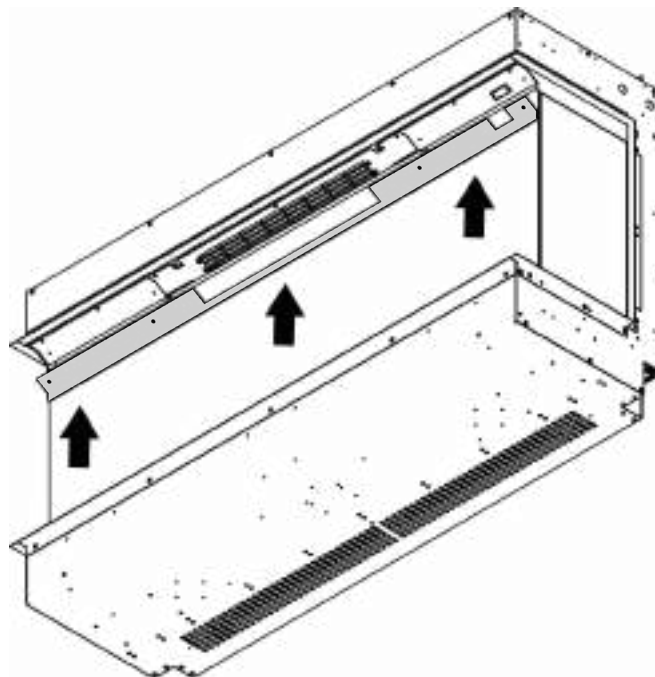

REMOTE OPERATION

The remote handset comes pre-connected to the fireplace via Bluetooth. Simply remove the remote from its outer packaging, turn the fire to the **ON** position, and the remote will fully control your appliance. Please see below to identify the buttons and their functions. **Please note: The FX button located on the remote control is not applicable with these models.**



Top Left - Turn your fire ON and OFF



Middle Right - Turn your heater OFF



Top Right - Turn your feature lights ON and OFF



Bottom Left - Adjust the brightness.



Middle Left - Turn your heater ON



WARRANTY

Aura Fires 2-year warranty – 1 year parts & labour. Recieve an additional year by registering your Aura fireplace online - www.aurafires.co.uk

To receive your Extended Warranty your product must be registered with within one month of the purchase date or installation date. The commencement date for the warranty period is the date of purchase.

During the registration process, the details of the Retailer / Supplier from whom you purchased your product will be required for your Extended Warranty to be activated.

Any product purchased not registered within the stated time will carry a standard 12-month warranty, or minimum statutory warranty for your country. The Extended Warranty for your Aura product extends the standard 12-month warranty by a further 12 months to a total warranty period of 2 years.

You can register your purchase via the registration card supplied, or by registering your product online, and choosing to opt-in we can keep you up-to-date with useful technical updates or the latest product information that will help you gain even more enjoyment from your new Aura product.

It is a condition of the Extended Warranty that the installation complies with relevant Building Regulations and the rules in force, and is carried out in accordance with the Installation Instructions.

This Warranty can be transferred in the event that the Customer sells the appliance within the Warranty period. The Customer must inform Aura Fires in writing of the sale within 14 days of the resale. Failure to notify Aura Fires within 14 days will result in the Warranty becoming invalid. Please pass on the dated sales receipt as a proof of purchase to the new owner.

The product must be adequately serviced and maintained. This may include, but is not limited to, cleaning the filters and maintaining the silks. Please see your Aura Fires Installation and Operating Instructions for further information on how to service and maintain your Electric appliance.

During your extended warranty period, only genuine Aura Fires spare parts must be used in the servicing and maintenance of your Stove or Fireplace, these spare parts can be ordered from www.aurafires.co.uk in the UK, or from an Expert Supplier directly.

Consumable items such as glass, screens, bulbs, LED boards, filters and batteries which are either subject to normal wear and tear or parts that require replacement in connection with normal maintenance are not covered either by the original or the Extended Warranty.

Should you experience problems with your Aura product, any claim must be submitted first to the Retailer / Supplier from whom the product was purchased. Your Retailer / Supplier will either be able to offer immediate assistance, or having visited you, make contact with Aura Fires on your behalf.

WARRANTY

For a Service call to be arranged Aura Fires will require proof of registration. Any Warranty claim without the required information will be referred back to your Retailer / Supplier from whom you purchased it.

To progress any Warranty claims for damaged appliance/parts, paint or any visual defects, photographic or video evidence must be supplied. Failure to provide photographic evidence may result in the claim being delayed or refused.

A service call will only be logged once the retailer or installer has inspected the appliance and verified that there is a manufacturing fault. Any visit by a Aura Fires Engineer or approved third party will incur a service charge if, the engineer inspects the appliance and concludes there is no manufacturing fault.



1, Evonic House, Clifford Park, Clifford Lane,
Stratford-on-Avon, CV37 8HW

Tel: +44 (0)1789 263868 Fax: +44 (0)1789 293080

Email: sales@aurafires.co.uk

www.aurafires.co.uk