



STOVE RANGE

INSTRUCTION MANUAL

FINSTALL
DODFORD



CONTENTS

EU Directives and UKCA Standards.....	3
Important information and Health & Safety.....	4
Checks before installation.....	5
Installation.....	6
Glass installation	7
Log layout.....	8
Remote operation	9
Warranty	10

The following materials and components should be disposed of in accordance with the below table.

Metal - Steel or cast iron	Can be taken to a local recycling centre for reuse to reduce waste going to landfill.
Glass & Screens	Can be taken to a local recycling centre for reuse to reduce waste going to landfill.
Vermiculite	Non hazardous material. Vermiculite can be crushed up and used for plant bedding and ash used for composting or disposed of at a local recycling centre for reuse to reduce waste going to landfill.
Electrical components - Fans, heater elements, PCB's, Power pack's, LED's	Dispose at a local recycling centre In accordance with latest WEEE directive.
Log fuel effects	These logs contain refractory ceramic fibre materials which requires disposal in accordance with WEEE legislation.
Natural Wood	Can be taken to a local recycling centre for reuse to reduce waste going to landfill.

EU DIRECTIVES

All Aura Fires products meet the requirements of the EC Directives. These directives have been met by compliance with the following standards:

EU 2011-65/EU 2015/863 Restriction of Hazardous Substances.

References to the relevant designated standards used:

EN 55014-1:2006 + A1:2009 + A2:2011 Electromagnetic Compatibility.

EN 55014-2:2015 Electromagnetic Compatibility.

EN 61000-3-2:2014 Electromagnetic Compatibility (EMC). Limits. Limits for Harmonic Current Emissions.

EN 61000-3-3:2013 Electromagnetic Compatibility (EMC). Limits. Limitation of Voltage Changes, Voltage Fluctuations and Flicker.

EN 60335-1:2012 + A11:2014 Household and similar electrical appliances - Safety

EN 60335-2-30:2009+A11:2012 Household and similar electrical appliances. Safety. Particular requirements for room heaters

UKCA STANDARDS

All Aura Fires products are in conformity with the relevant UK Statutory Instruments (and their amendments).

2016 No. 1101 The Electrical Equipment (Safety) Regulations 2016

2016 No. 1091 The Electromagnetic Compatibility Regulations 2016

2012 No. 3032 The Restriction Of Use Of Certain Hazardous Substances In Electrical And Electronic Equipment Regulations 2012



IMPORTANT INFORMATION AND HEALTH & SAFETY

When using electrical appliances, basic precautions should always be followed to reduce the risk of fire, electric shock, and injury to persons, including the following:

- Read all of the instructions carefully before using the appliance, only use this appliance as described in this manual. Any other use not recommended by the manufacturer may cause injury to persons, or damage to the appliance.
- Remove all packaging and dispose of it at an appropriate recycling facility.
- When transporting or storing the appliance and power lead, keep in a dry place, away from excessive vibration and store so as to avoid damage.
- This fireplace is hot when in use. To avoid burns, do not let bare skin touch hot surfaces. The trim around the heater outlet becomes hot during heater operation. DANGER: High temperatures may be generated under certain abnormal conditions.
- Do not install this appliance immediately in front of a fixed socket outlet.
- Do not install this appliance in the immediate surroundings of a bath, shower, swimming pool or any other area where the appliance could come into contact with water or humidity, e.g. a bathroom.
- Do not use in areas where gasoline, paint, or any flammable liquids are used or stored.
- This appliance is only suitable for indoor use, do not use outdoors.
- Do not cover the appliance, or let the air inlet/outlet to be obstructed in any way as it may overheat.
- Keep the power lead away from hot surfaces and the heater outlet. Do not route the power lead in front of the appliance, or under any carpets or rugs. Do not allow the power lead to be coiled up once installed, as this can cause overheating.
- This appliance must be firmly fixed to or recessed into, a flat internal wall.
- A maintenance hatch must be installed into the surrounding installation to allow future access.
- Always use a certified electrician should new circuits or outlets be required. And always use properly grounded, fused and polarised outlets.
- Where the power lead passes through any masonry wall, stone surround etc. ensure that suitable rubber bushes are fitted at any possible wear points.
- If the power lead is damaged do not use the appliance until it has been replaced.
- Do not use any external switching device, timers, or extension leads. Do not connect the appliance to a circuit that is frequently switched on and off by the utility.
- In the event of a malfunction, switch off the appliance, and disconnect it from the mains power supply. Have the appliance inspected by a certified electrician before reusing.
- Do not use the appliance if it is damaged. In the event of any damage to the appliance, please contact the retailer from whom the appliance was purchased.
- Any repairs must only be performed by a certified electrician.
- Extreme caution is necessary when any heater is used by, located near children or people of reduced mobility, and whenever the unit is left operating and unattended.
- Young children should be supervised to ensure that they do not play with the appliance.
- Disconnect from the power supply before performing any cleaning, maintenance or relocation of the unit. Do not use steam cleaners, or aerosols near the appliance.
- Do not burn wood or anything else in this appliance.
- Do not strike the glass. The glass used is toughened safety glass, if broken it will shatter into small chunks which are less likely to cause injury.
- Do not drill or screw any new holes into the appliance.

CHECKS BEFORE INSTALLATION - ALL MODELS

INSTALLATION DO'S AND DONT'S

Before installing the appliance please read and take into account the following important requirements;

- Consult a qualified professional to check the structure of the installation site.
- If installing into an existing chimney, make sure to adequately block off the flue.
- The appliance must never be installed in front of an electrical socket.
- The appliance must not be installed anywhere that it may come into contact with water, i.e. a bathroom.
- Do not wet plaster directly onto the appliance.

CHECKS BEFORE INSTALLATION

We recommend turning on the appliance before installation, connect the appliance to a power source using the provided electrical lead, and depress the right side of the **ON/OFF** switch.

Remove the electrical lead from the wall and continue with the installation.

Please note: The image below shows the Dodford model. Not all stoves have the same ON/OFF switch and Power Inlet location. ON/OFF switch locations and Power Inlet locations for all models can be found on page 6.

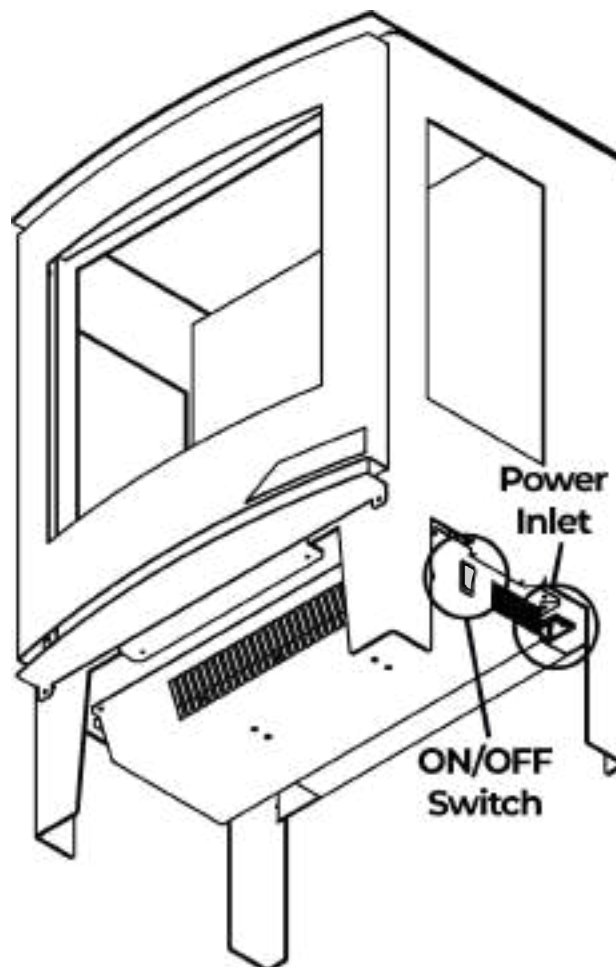

STOVE INSTALLATION

FREE-STANDING

The following models are free-standing appliances, which means that they can be situated almost anywhere without any installation. Once the outer packaging has been removed and the product has been tested (see page 5), the below models can then be placed in situ. Be sure to locate them as close to a plug socket as possible to avoid the power lead running along the floor and becoming a trip hazard.

FINSTALL

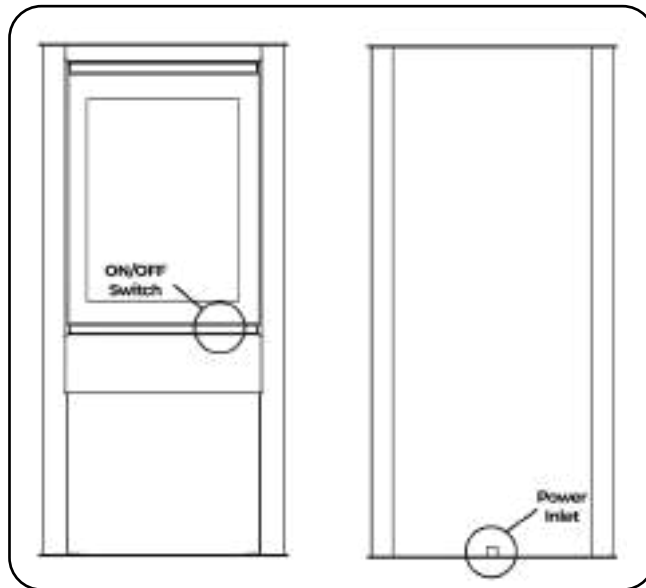

DODFORD

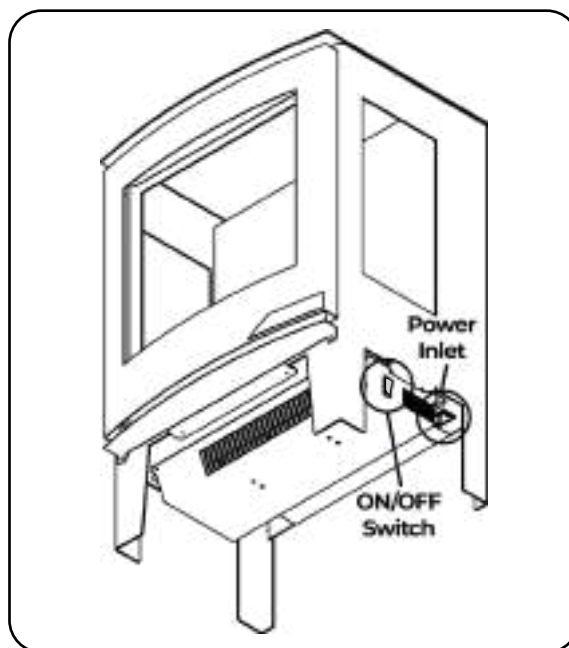

GLASS INSTALLATION

SLOTTED INSTALL

The slotted install of the front glass applies to the both the Dodford and Finstall. The model shown in this example is the Dodford but the process is the same for both models.

1

To install the front glass first locate the four keyhole slots on the front of the appliance, and the four screws on the back of the front glass.

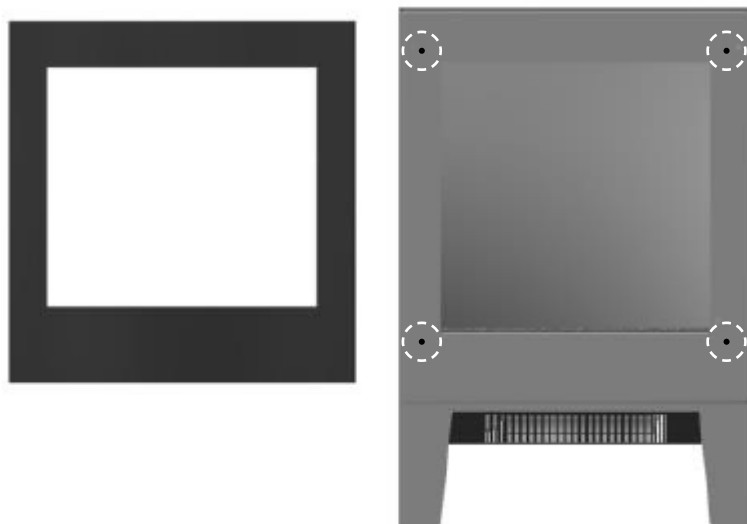

2

Now line up the screws and screw holes and slot them into each other, then allow the glass to drop into place. In the event the front doesn't drop into place, you may have to push it down into place.

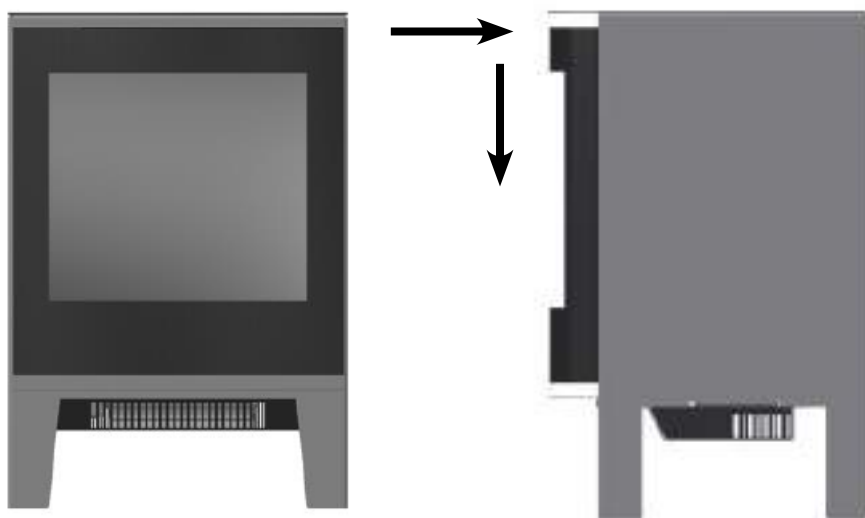

LOG LAYOUTS

When you have your appliance installed you can set up your log set/s. There is no right or wrong way to arrange your logs, the following images are an example of how you could lay them out. Both models use the same log set.



REMOTE OPERATION

The remote handset comes pre-connected to the fireplace via Bluetooth. Simply remove the remote from its outer packaging, turn the fire to the **ON** position, and the remote will fully control your appliance. Please see below to identify the buttons and their functions. **Please note: The FX button located on the remote control is not applicable with these models.**



Top Left - Turn your fire ON and OFF



Middle Right - Turn your heater OFF



Top Right - Turn your feature lights ON and OFF



Bottom Left - Adjust the brightness.



Middle Left - Turn your heater ON

WARRANTY

Aura Fires 2-year warranty – 1 year parts & labour. Recieve an additional year by registering your Aura fireplace online - www.aurafires.co.uk

To receive your Extended Warranty your product must be registered with within one month of the purchase date or installation date. The commencement date for the warranty period is the date of purchase.

During the registration process, the details of the Retailer / Supplier from whom you purchased your product will be required for your Extended Warranty to be activated.

Any product purchased not registered within the stated time will carry a standard 12-month warranty, or minimum statutory warranty for your country. The Extended Warranty for your Aura product extends the standard 12-month warranty by a further 12 months to a total warranty period of 2 years.

You can register your purchase via the registration card supplied, or by registering your product online, and choosing to opt-in we can keep you up-to-date with useful technical updates or the latest product information that will help you gain even more enjoyment from your new Aura product.

It is a condition of the Extended Warranty that the installation complies with relevant Building Regulations and the rules in force, and is carried out in accordance with the Installation Instructions.

This Warranty can be transferred in the event that the Customer sells the appliance within the Warranty period. The Customer must inform Aura Fires in writing of the sale within 14 days of the resale. Failure to notify Aura Fires within 14 days will result in the Warranty becoming invalid. Please pass on the dated sales receipt as a proof of purchase to the new owner.

The product must be adequately serviced and maintained. This may include, but is not limited to, cleaning the filters and maintaining the silks. Please see your Aura Fires Installation and Operating Instructions for further information on how to service and maintain your Electric appliance.

During your extended warranty period, only genuine Aura Fires spare parts must be used in the servicing and maintenance of your Stove or Fireplace, these spare parts can be ordered from www.aurafires.co.uk in the UK, or from an Expert Supplier directly.

Consumable items such as glass, screens, bulbs, LED boards, filters and batteries which are either subject to normal wear and tear or parts that require replacement in connection with normal maintenance are not covered either by the original or the Extended Warranty.

Should you experience problems with your Aura product, any claim must be submitted first to the Retailer / Supplier from whom the product was purchased. Your Retailer / Supplier will either be able to offer immediate assistance, or having visited you, make contact with Aura Fires on your behalf.

WARRANTY

For a Service call to be arranged Aura Fires will require proof of registration. Any Warranty claim without the required information will be referred back to your Retailer / Supplier from whom you purchased it.

To progress any Warranty claims for damaged appliance/parts, paint or any visual defects, photographic or video evidence must be supplied. Failure to provide photographic evidence may result in the claim being delayed or refused.

A service call will only be logged once the retailer or installer has inspected the appliance and verified that there is a manufacturing fault. Any visit by a Aura Fires Engineer or approved third party will incur a service charge if, the engineer inspects the appliance and concludes there is no manufacturing fault.



1, Evonic House, Clifford Park, Clifford Lane,
Stratford-on-Avon, CV37 8HW

Tel: +44 (0)1789 263868 Fax: +44 (0)1789 293080

Email: sales@aurafires.co.uk

www.aurafires.co.uk