



DRAYTON

INSTRUCTION MANUAL



AC 220V-240V 50Hz 1400-1600W

⚠ WARNING

Read and understand this entire owner's manual, including **all safety information**, before plugging in or **using** this product. Failure to do so could result in **fire, electric shock, or serious personal injury**.

⚠ CAUTION

Keep this owner's manual for future reference. If you sell or give this product away, **make sure this manual accompanies this product**.

CONTENTS

Disposal.....	2
Directives & Standards.....	3
Preparation.....	4
Dimensions.....	5
Recessed to wall Install.....	6
Wall-mounted Install.....	8
Methods of Operation.....	10
Remote Control.....	11
E-smart App Setup.....	12
Using the App.....	14
Control Overview.....	15
Programming the Timer.....	16
Problems Connecting.....	17
Connecting to Amazon Alexa.....	18
Connecting to Google Assistant.....	20
Voice Control Commands.....	22
Retro-fitting the Remote Control.....	23
Warranty.....	24
Notes.....	26

The following materials and components should be disposed of in accordance with the below table.

Metal - Steel or cast iron	Can be taken to a local recycling centre for reuse to reduce waste going to landfill.
Glass & Screens	Can be taken to a local recycling centre for reuse to reduce waste going to landfill.
Vermiculite	Non hazardous material. Vermiculite can be crushed up and used for plant bedding and ash used for composting or disposed of at a local recycling centre for reuse to reduce waste going to landfill.
Electrical components - Fans, heater elements, PCB's, Power pack's, LED's	Dispose at a local recycling centre In accordance with latest WEEE directive.
Log fuel effects	These logs contain refractory ceramic fibre materials which requires disposal in accordance with WEEE legislation.
Natural Wood	Can be taken to a local recycling centre for reuse to reduce waste going to landfill.

EU DIRECTIVES

All Aura Fires products meet the requirements of the EC Directives. These directives have been met by compliance with the following standards:

EU 2011-65/EU 2015/863 Restriction of Hazardous Substances.

References to the relevant designated standards used:

EN 55014-1:2006 + A1:2009 + A2:2011 Electromagnetic Compatibility.

EN 55014-2:2015 Electromagnetic Compatibility.

EN 61000-3-2:2014 Electromagnetic Compatibility (EMC). Limits. Limits for Harmonic Current Emissions.

EN 61000-3-3:2013 Electromagnetic Compatibility (EMC). Limits. Limitation of Voltage Changes, Voltage Fluctuations and Flicker.

EN 60335-1:2012 + A11:2014 Household and similar electrical appliances - Safety

EN 60335-2-30:2009+A11:2012 Household and similar electrical appliances. Safety. Particular requirements for room heaters

UKCA STANDARDS

All Aura Fires products are in conformity with the relevant UK Statutory Instruments (and their amendments).

2016 No. 1101 The Electrical Equipment (Safety) Regulations 2016

2016 No. 1091 The Electromagnetic Compatibility Regulations 2016

2012 No. 3032 The Restriction Of Use Of Certain Hazardous Substances In Electrical And Electronic Equipment Regulations 2012



PREPARATION







This product includes a **GLASS panel!** Always use **extreme caution** when handling **glass**. Failure to do so could result in **personal injury** or **property damage**.

Remove all parts and hardware from the carton and place them on a clean, soft, dry surface. Parts and assembly steps are grouped for wall-hanging or recessing use. Check the parts list to make sure nothing is missing. Dispose of packaging materials properly. Please recycle whenever possible.

You will need the following tools (not included): Phillips screwdriver; stud finder; level; tape measure; electric drill; 1/4" wood drill bit, hammer.

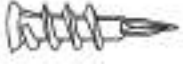
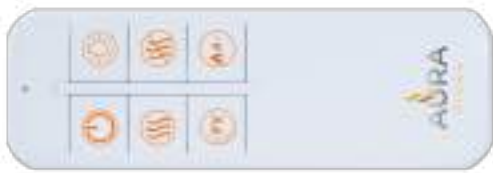
PARTS AND HARDWARE

 <p>A – Fireplace</p>			
	<p>B – Wood Screws</p>		<p>C – Drywall anchors</p>
			
			
<p>E-Wall Bracket Fixed on back of firebox</p>	<p>D - Log Mould Fixed into firebox</p>		

SPECIFICATION AND DIMENSIONS

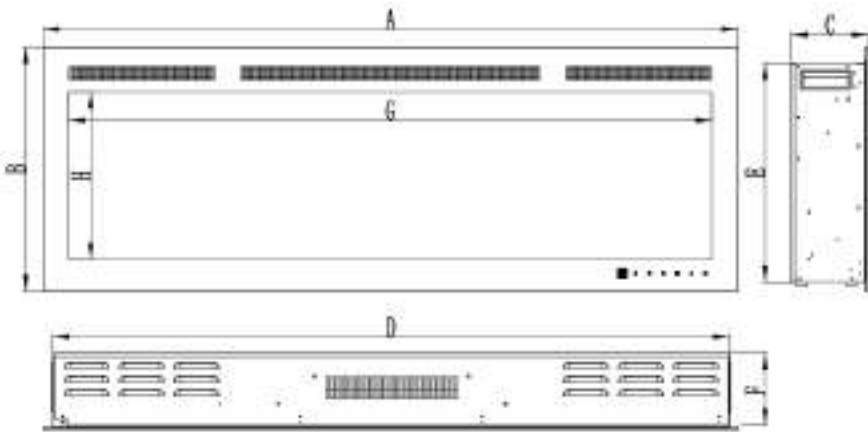

Description	Electric Fireplace
Type	2 Way Mounting Unit Wall-Mount, Recess into Wall
Voltage	220-240V AC
Watts	1400-2000W
Amps	10AMP Grounded Circuit

PRODUCT DIMENSIONS

Model Number	A	B	C	D	E	H	G
Drayton 50	49-3/4" [1262mm]	17-7/16" [443mm]	5- 1/2" [140mm]	48- 7/16" [1230mm]	15- 5/8" [397mm]	12" [306mm]	46" [1168mm]
Drayton 60	59-3/4" [1516mm]	17-7/16" [443mm]	5- 1/2" [140mm]	58- 7/16" [1484mm]	15- 5/8" [397mm]	12" [306mm]	56" [1422mm]

INSTALLATION AND ASSEMBLY

Your appliance is a wall-mounted, recessed and/or mantel installed appliance. Select a suitable location that is

not susceptible to moisture and is away from drapes, furniture and high traffic areas.

NOTE: Follow all National and local electrical codes.

MINIMUM CLEARANCE TO COMBUSTIBLES

Measurements are taken from the glass front.			
Bottom	0"	Top	8" (300mm) to mantel
Sides	0"	Top	8" (300mm) to ceiling
Back	0"		

MINIMUM MANTEL CLEARANCES

WARNING

WHEN USING PAINT OR LACQUER TO FINISH THE MANTEL, THE PAINT OR LACQUER MUST BE HEAT RESISTANT TO PREVENT DISCOLOURATION.

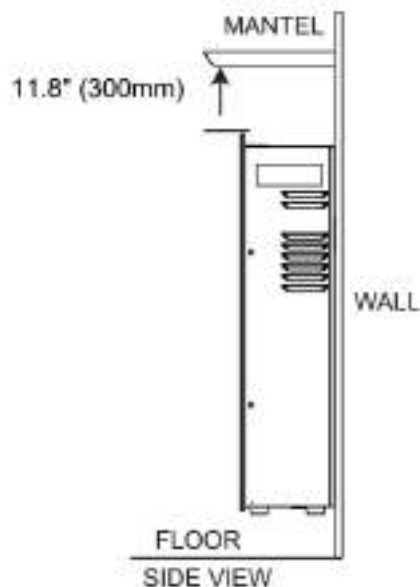

RECESSED TO WALL INSTALLATION

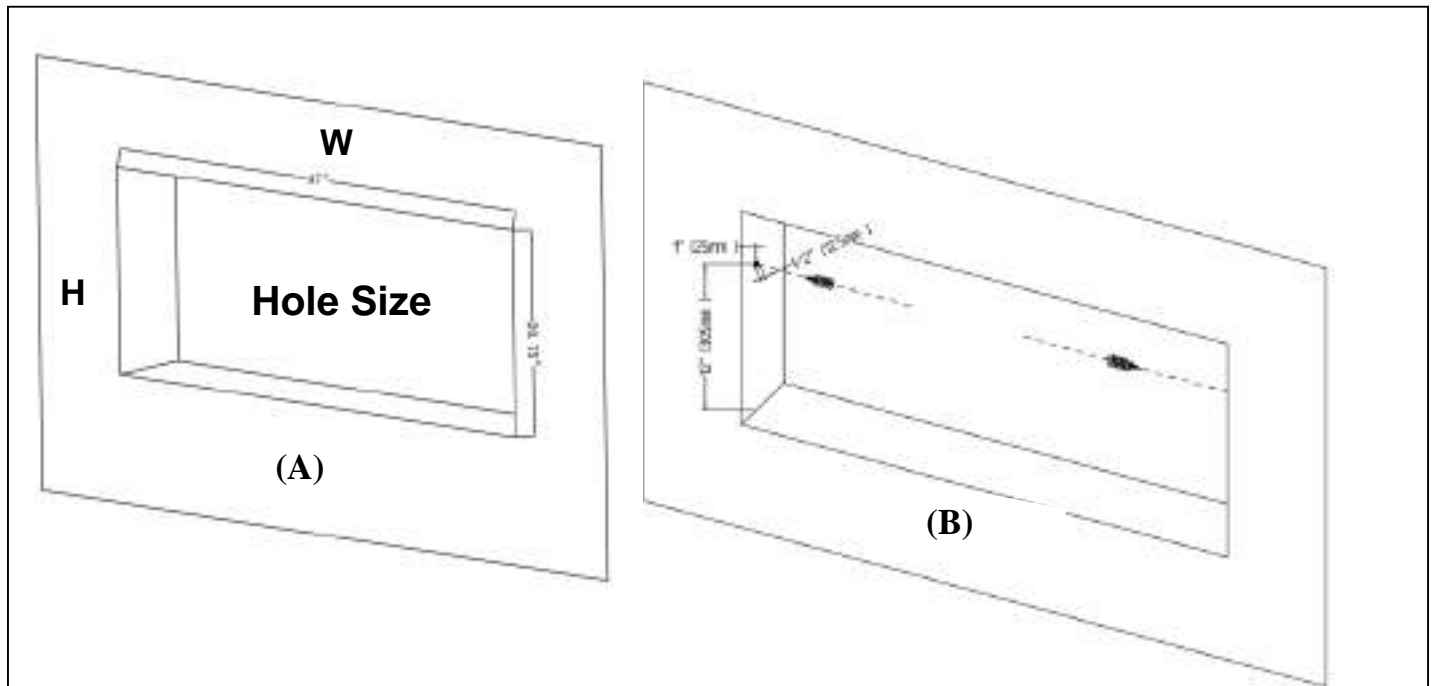

STEP A. Selection a dry wall to open a hole for fireplace box. Size of hole as below chart **Figure (A)**

Framing Hole Size		
Model Number	W	H
HK-50HZ	48- 3/4" [1238mm]	15- 3/4" [400mm]
HK-60HZ	58- 3/4" [1492mm]	15- 3/4" [400mm]

STEP B. Fix the wall anchors in each side of the fireplace box according to the dimensions showed on the drawing. **Figure (B)**

RECESSED TO WALL INSTALLATION

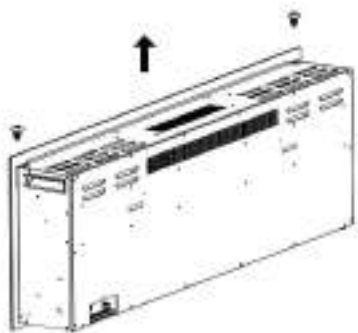

(C)

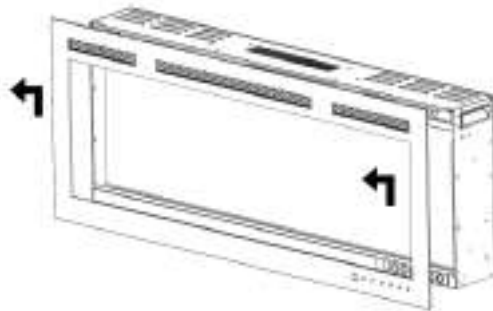

(D)

STEP C. Take off the screw in both sides of the glass panel. **Figure (C)**

STEP D. Have two persons to take the glass panel out of the fireplace box. Place it to a soft and clean place. **Figure (D)**

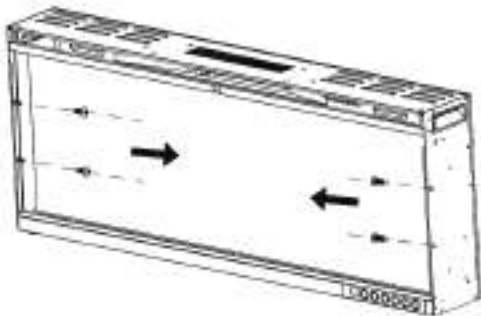

(E)

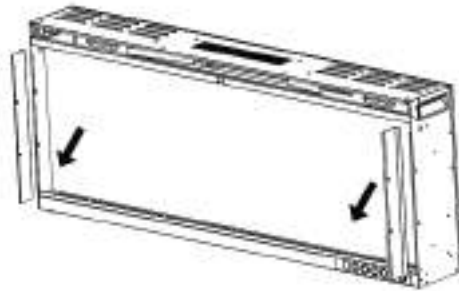

(F)

STEP E. Take off the two screws in both sides, then take off the two metal brackets, keep them well as you will need to screw back. **Figure (E, F)**

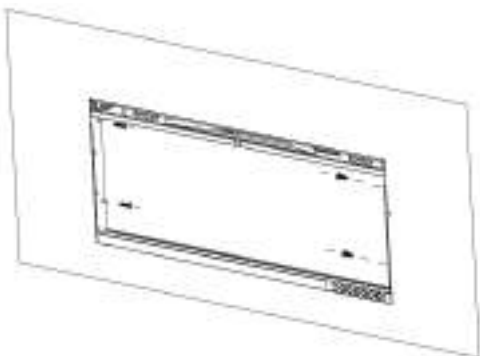

(G)

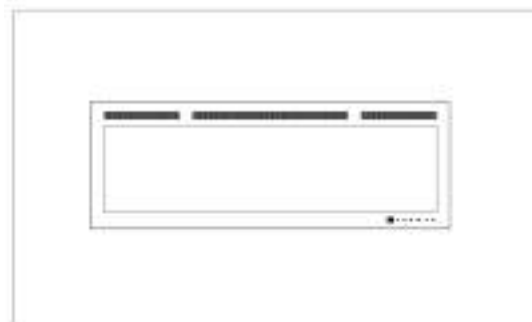

(H)

STEP F. Have two persons to move the fireplace box to the wall hole. With the appliance is fully recessed into the wall.

- Use the 2 screws (provided) to lock the appliance into the wall with the existing two sides see **Figure (G)**
- Install the media and re-install the glass front. **Figure (H)**

WALL-MOUNTED INSTALLATION

Due to the many different materials used on different walls, it is highly recommended that you consult your local builder before you install this appliance on the wall.

A. Select a location that is not prone to moisture and is located at least 36" (914mm) away from combustible materials such as curtain drapes, furniture, bedding, paper, etc.

B. Have two people hold the appliance against the wall to determine the final location.

C. Place unit face down on a soft, nonabrasive surface. Remove the bracket from the back of the unit by removing the screws, refer to Figure 1.

D. Mark out location, then mount the bracket(s) onto the wall using the supplied screws. This bracket

MUST have the hooks facing upward and be level. **NOTE: It is strongly**

recommended that the mounting bracket (E) be Screwed into the wall studs

Where possible. If the wall Studs cannot be used, ensure

That the supplied plastic anchors are used to affix the bracket to the wall and the bracket is adequately secured.

E. With the wall mounting bracket installed have two people lift the appliance up and insert the two hooks

on the bracket into the two slots on the back of the appliance.

F. Check the appliance for stability ensuring that the bracket will not pull free from the wall.

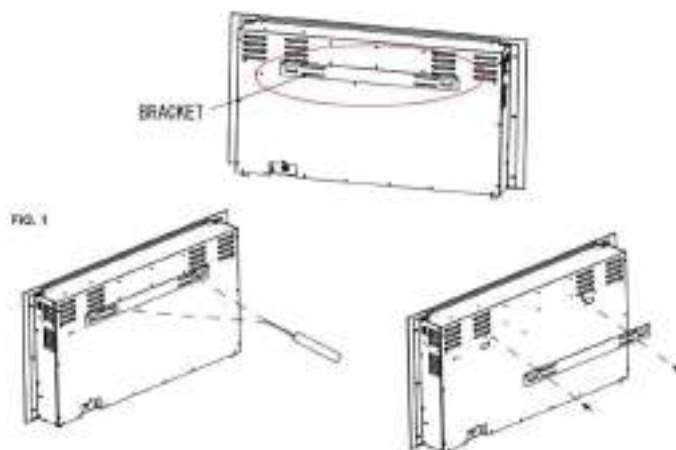

Wall Bracket Illustrated

AURA

FIRES



METHODS OF OPERATION

There are two ways to control all the features of your Evonic appliance - **remote** or **e-smart App**



Our remote handset comes automatically paired and ready to operate straight out of the box. If you choose to control your appliance via the E-smart Cloud App your internet router and smart device should meet the following minimum requirements -

Wi-Fi Router

- Compatible with IEEE 802.11n/g/b
- WPA2 encryption
- Radio frequency: 2.4GHz band
- Wireless auto channel: auto search for wireless LAN radio channel free of interference
- Support for the User Datagram Protocol (UDP)
- The minimum distance from your internet router to the fireplace should be 70cm

Smart Device

- Minimum device requirements IOS 8.0 or Android 10

REMOTE CONTROL

The remote handset comes pre-connected to the fireplace via Bluetooth. Simply remove the remote from its outer packaging, turn the fire to the **ON** position, and the remote will fully control your appliance. Please see below to identify the buttons and their functions.



Top Left - Turn your fire **ON** and **OFF**



Top Right - Turn your feature lights and overbed illumination **ON** and **OFF**



Middle Left - Turn your heater **ON**



Middle Right - Turn your heater **OFF**



Bottom Left - Change the flame animation.



Bottom Right - Adjust the brightness.

With the remote control the heater is pre-set to **28°**, if you would like to adjust the temperature you need to do this through the app.

The brightness button adjusts the brightness of the fire by **0%**, **25%**, **50%**, and **100%**.

SETTING TIMERS USING THE REMOTE CONTROL

You can set up timers for your appliance easily by using your remote control.

Once you have turned your fire on using the remote, simply press the **Heater ON** icon to set a 15 minute timer. Each click of the **Heater ON** button adds another 15 minutes to the timer and this can be used for a total of 90 minutes (6 clicks).

E-SMART APP SETUP



1

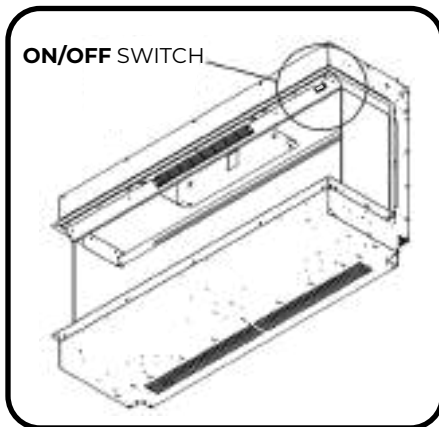

Make sure that your fire is plugged in and the switch is on. Then turn on your fire by pressing the ON/OFF switch to the 'ON' position.

2



Download the **E-Smart Cloud** app from the Apple Store, or Google Play Store.

3

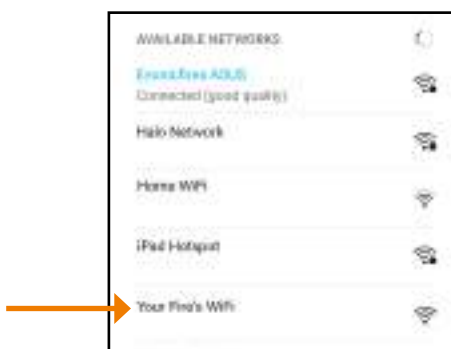

Open the Settings panel on your device and connect to the fire's wireless connection. The name of the fire's wi-fi will vary depending on the model.

4



Open the E-Smart app on your device

CONTINUED



5

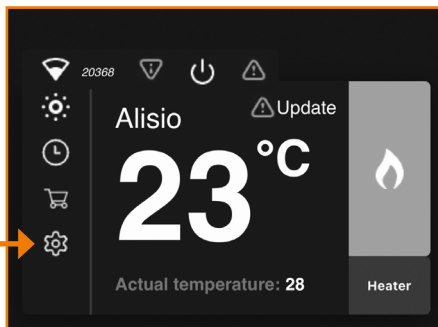

Open the settings panel on the app's Home Screen.

6

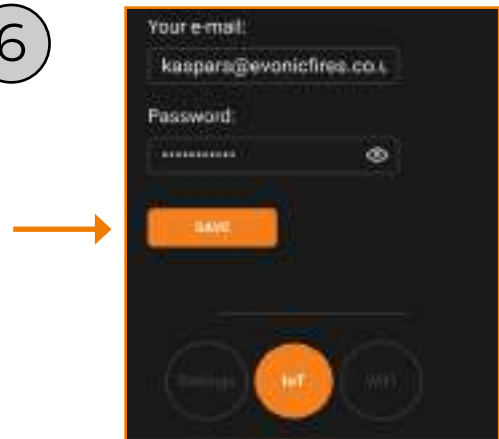

Scroll down to the 'IoT Registration' section and fill in your email address and create a password. Press 'Save'. Then select the grey wi-fi button.

7

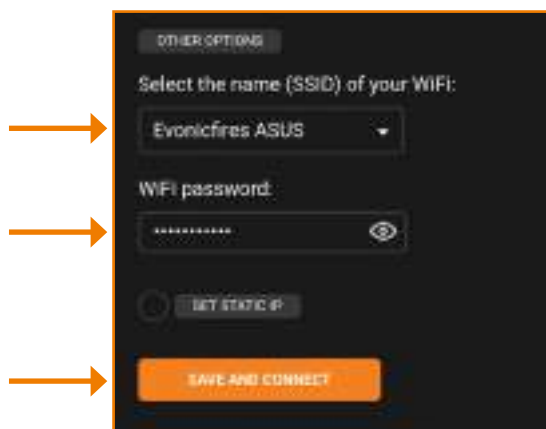

Select your router from the drop down box, and enter your router's password. Press the eye icon to double check for mistakes. Press 'Save and Connect'. Only select Static IP if advised by an IT professional.

8



The pairing process between your device, the fire, and your router will now take place. This may take a few minutes, and when the app shows 'Redirect' you may see the lighting on your fire change colour. This is completely normal. To complete the setup, turn your fire off then back on.

USING THE E-SMART APP

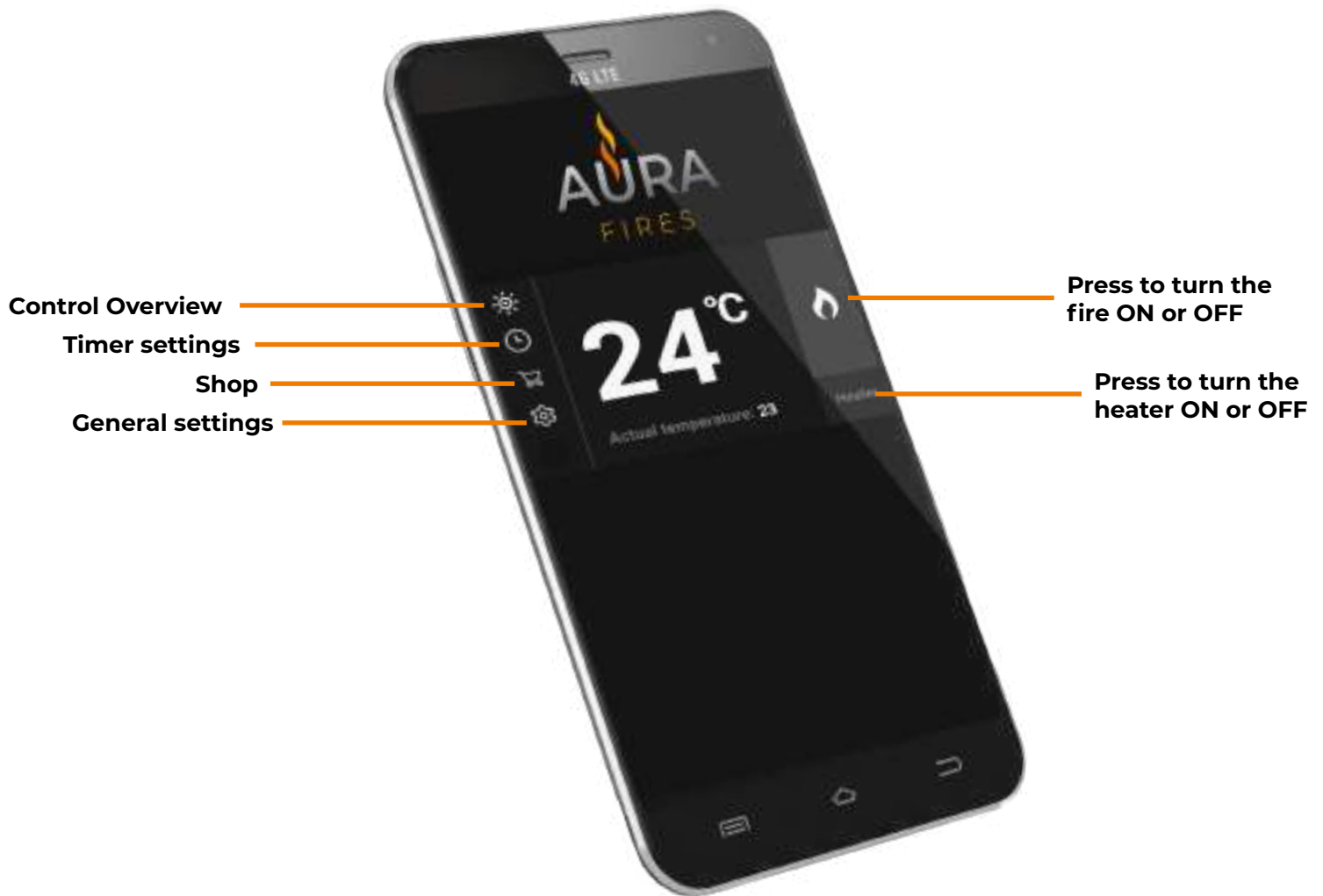

E-SMART APP SETUP

On the Home Page of the E-Smart Cloud App you can see the name of your fire, the chosen temperature, and the actual temperature. On the left hand side you can select the timer, shop, and app settings. On the right hand side you can turn the lights in the fire on and off, and also turn the heater on and off.

To enter the Control Overview either select the light bulb icon on the top left or the central temperature box.

CONTROL OVERVIEW

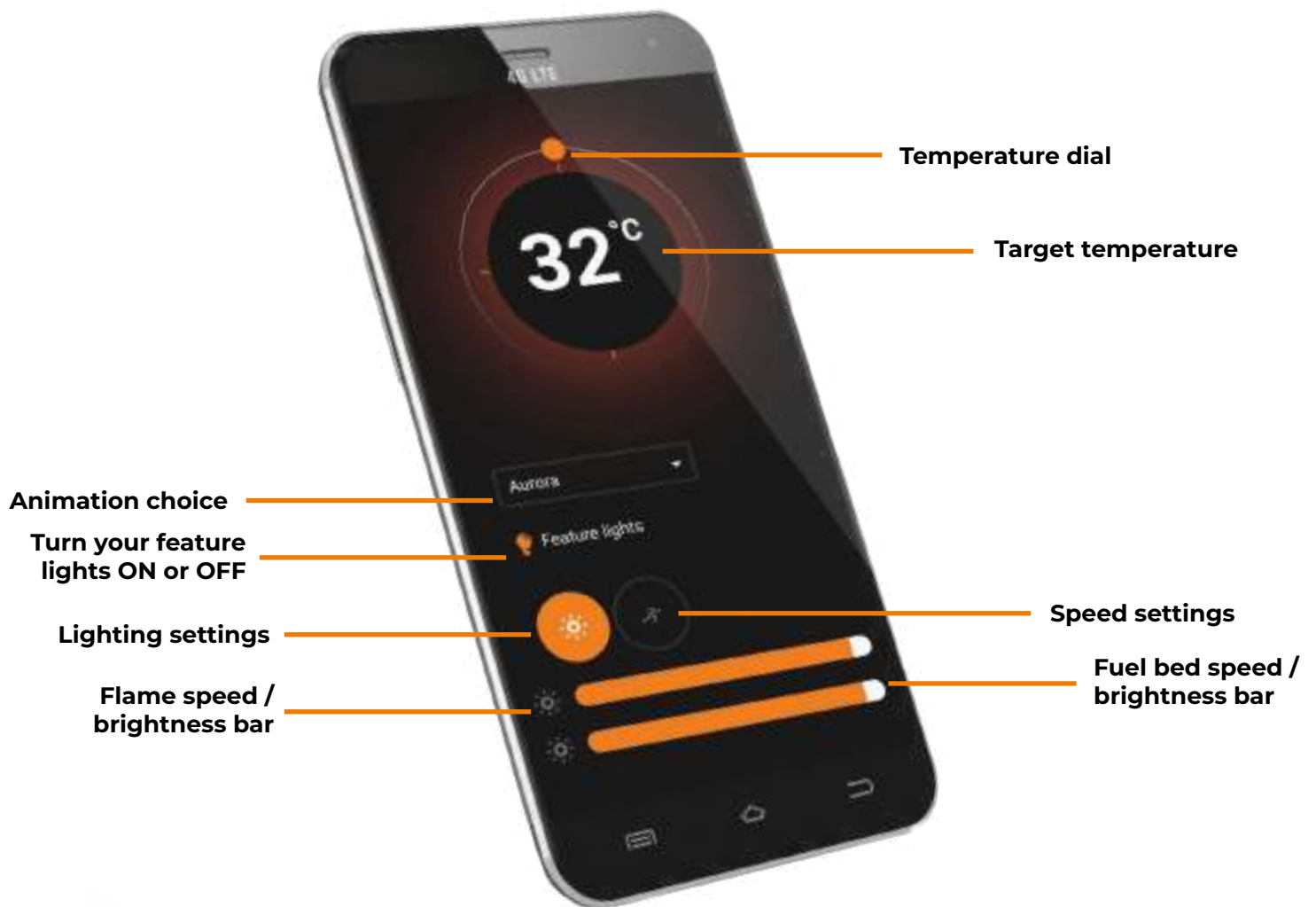

To adjust the desired temperature of your fire ensure that the heater is selected on the Home Page in the previous step. Then press, hold, and rotate the temperature dial to set the temperature.

The animation drop down allows you to choose the flame effect for your fire, more flame effects are available to download from our shop on the Home Page.

The 'Feature lights' button will activate the over fuel-bed lights, if you have a model with tile wings then this button will also turn on the side down-lighters.

By clicking on lighting settings you can adjust the flame brightness by pressing, holding, and sliding the tab at the bottom of the screen. Slide left to lower the brightness, and right to increase the brightness. You can adjust the fuel bed brightness in the same way with the lower tab slider.

To change the speed of the LED flame effect single press the speed setting option, and slide the top dial left to slow it down, and right to increase the speed. Likewise with the fuel bed speed, slide the lower tab left to slow it down and right to increase it.



PROGRAMMING THE TIMER

1

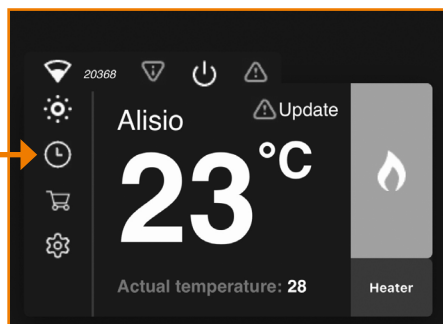

Single press the clock icon on the Home Page to begin programming the Timer.

2

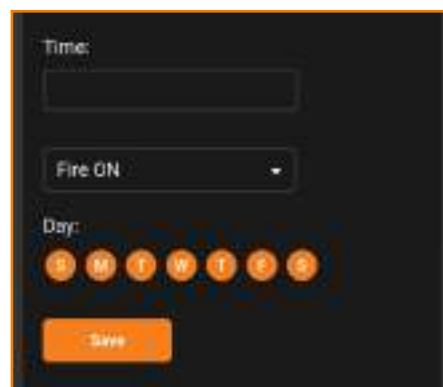

Input your desired time in the Time box, select the action (Fire On/Off/, Heater On/Off) you want. Deselect the day/s you don't want it to apply to, and press the Save button.

3

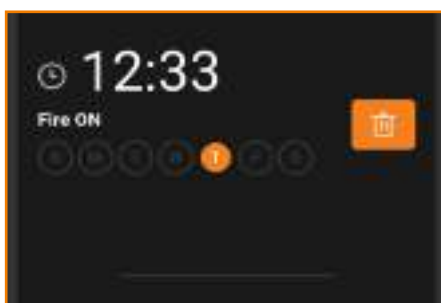

The above screen will now show your set timer. To delete the timer press the bin icon. To add an additional timer scroll down and repeat the process. Press the Back button to return to the Home Page.



UPDATING YOUR FIRE AND LOGGING OUT

Update your fire by clicking on the triangular icon. Do not turn your fire off until it is complete. It may take up to 10 minutes to update.

To log out of the e-smart cloud app, on your home screen you need to press the 'log out' icon.

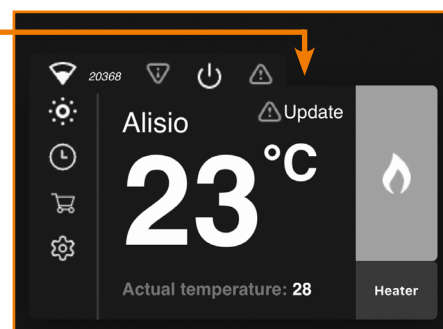



PROBLEMS CONNECTING

If you are having problems connecting your fire with your device and router please try the following steps to fix the issue.

- Switch fire **OFF**
- Switch wi-fi router **OFF**
- Switch fire back ON (Keeping router **OFF**)
- Open the wi-fi settings on your device - find and select your product / fire
- Open the e-smart App on your device and select the settings icon
- In '**Device Name**', rename your fire (Be sure not to use numbers or spaces when renaming your fire)
- In the Settings menu scroll down to the IoT Registration and check that your email and password are correct. You can click the **eye icon** to help you see any mistakes. Press save.
- Check you have selected the correct network and the wi-fi password entered is correct, you can click the **eye icon** to help you see any mistakes.
- Make sure '**Static IP**' is NOT selected (unless advised by an IT professional). Press save and connect.
- Wait 2 minutes for the fire to try and re-connect. Once this process is finished the App will show the home screen (Page 20).
- Switch your fire **OFF**.
- Switch your wi-fi router back **ON**.
- Switch your fire back **ON**.

If your wi-fi signal is weak, the App will show you a red warning message located on the home screen.

If your problems persist after attempting to re-connect, please contact our service department.



RESETTING YOUR FIRE

If you have entered a wrong email or password during the set-up process, then you may need to reset your fire to factory settings. To do this your fire must be updated to the latest version, you can do this by following the instructions on page 16.

Once your fire is fully updated you can reset it by turning it off and on at the power switch 5 times. Be sure to allow 1 second between each click. There will be an audible beep after this has been done, you can then continue with the set up process on page 12.



CONNECTING TO AMAZON ALEXA

1

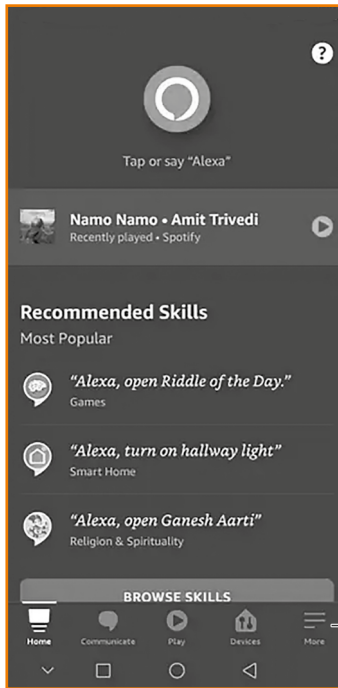

Once your fire is installed, and switched on, download and open the Amazon Alexa app. Once open single press More in the bottom right hand corner.

2

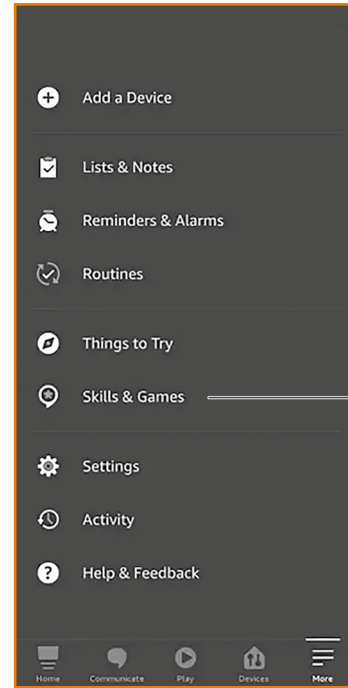

Single press Skills & Games on the pop up list.

3

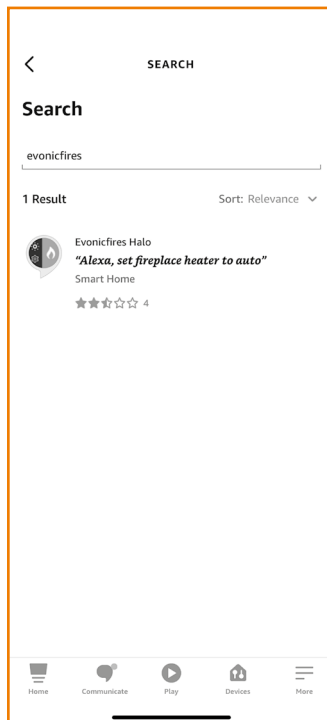

Single press Search and type in evonicfires. Select the Evonicfires Halo skill icon to open.

4

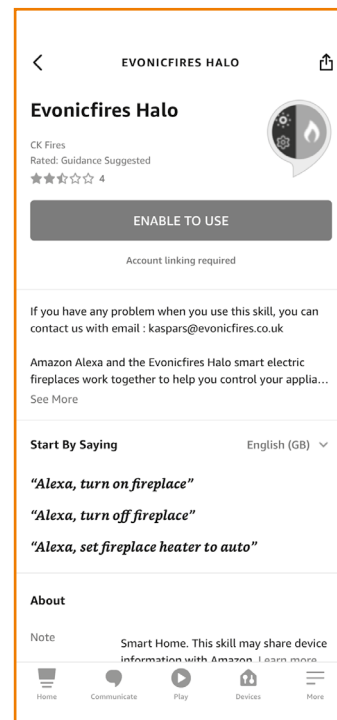

Now on the Evonicfires Halo skill page you can single press the Enable to Use button to go to the log in page.



CONTINUED...

5

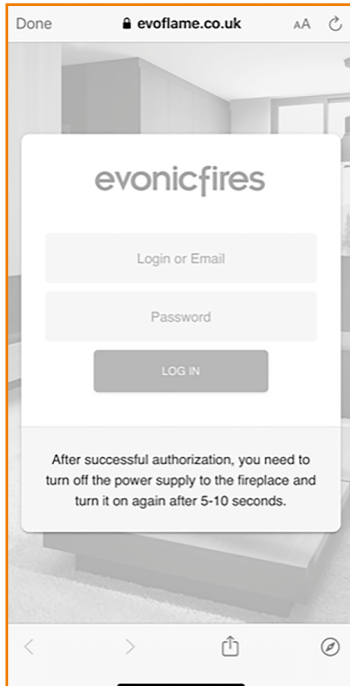

Enter the log in details that you previously entered in the app set up process, and single press Log In.

6

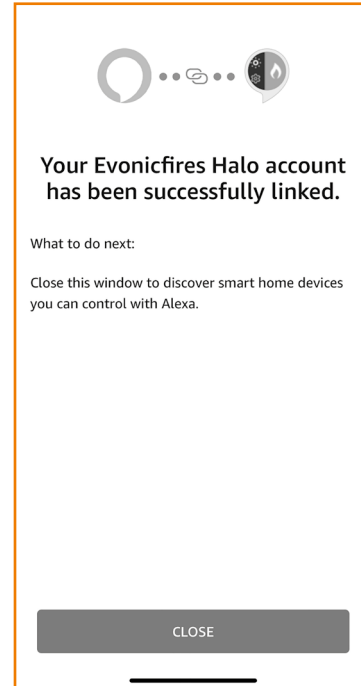

After a few moments your account will be linked, once this is done you can single press Close.

7



Single press Discover Devices to search for your fire.

8

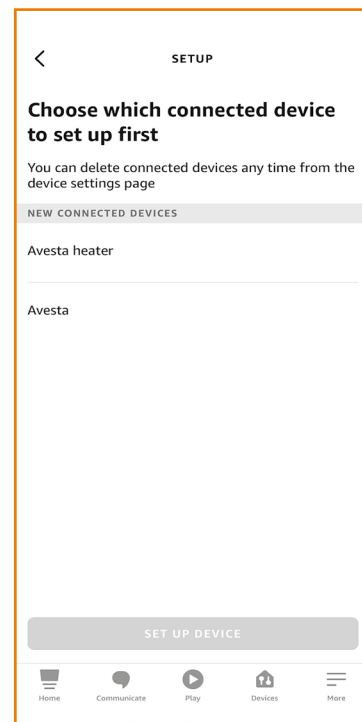

Your fire will show up as two devices, allowing you to programme the heater separately to the effects. Single press the second option, and Set up Device.



CONNECTING TO GOOGLE HOME

1

Single press plus symbol

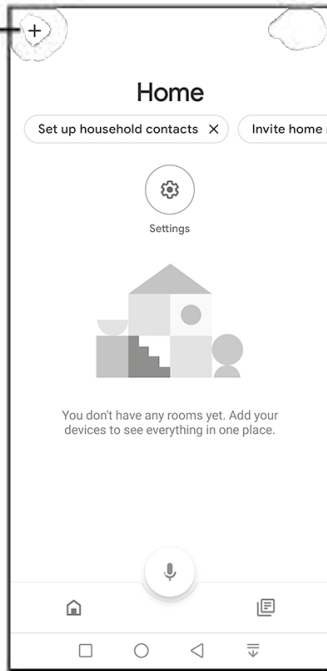

Once your fire is installed, and switched on, download and open the Google Home app. Once open single press the plus symbol in the top left hand corner.

2

Single press Set up Device

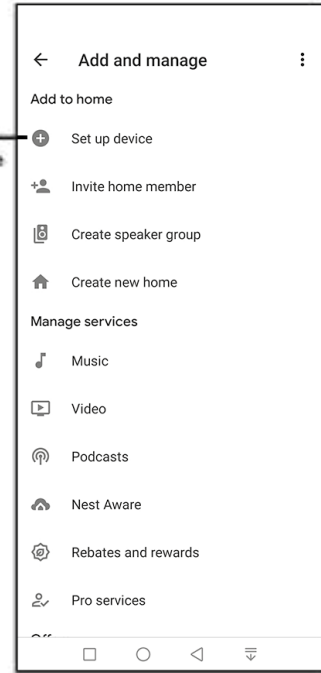

Single press Set up Device on the pop up list.

3

Single press Works with Google

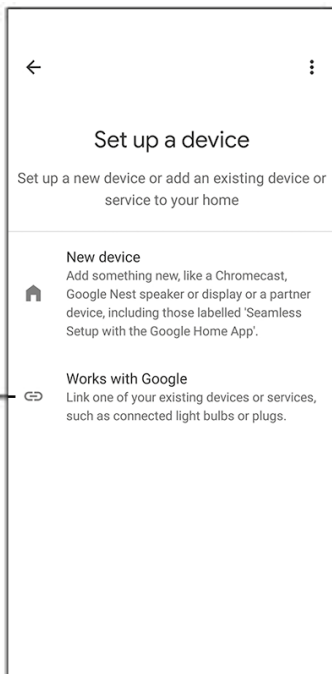

Single press Works with Google.

4

Single press Search



Single press the Search icon in the top right corner.



CONTINUED...

5

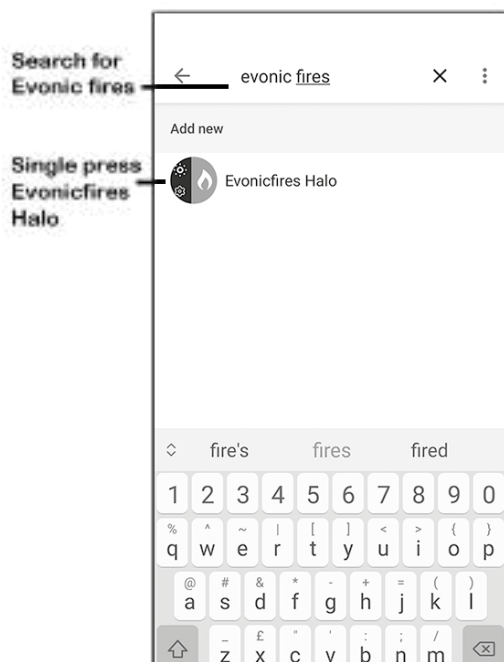

Type in Evonic Fires, single press search and then select the Evonic Fires E-Smart icon.

6

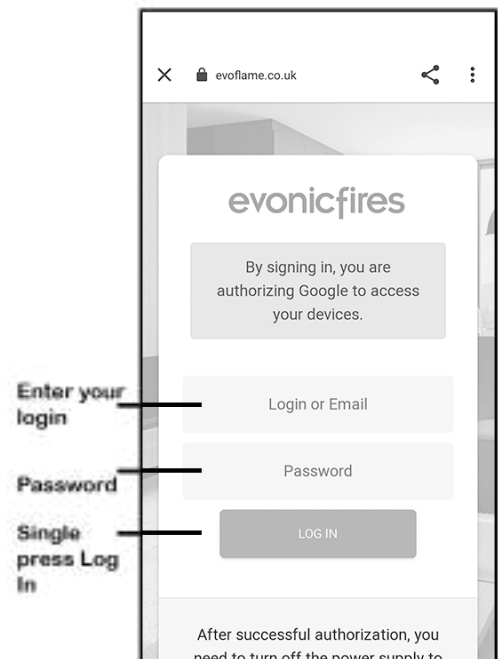

Once in the Evoflame log in page, enter the log in details that you previously entered in the app set up process, and single press Log In. Your appliance is now paired with Google Home!





COMMANDS FOR AMAZON ALEXA

When using Amazon Alexa or to control your appliance settings remember to substitute the words 'the fire' for whatever you have named your appliance.

TURNING THE APPLIANCE ON AND OFF

"Alexa, turn fire on."/ "Alexa, turn the fire off."

TURNING THE HEATER ON AND OFF

"Alexa, set fire heater to auto."/ "Alexa, set fire heater to off."

CHANGING THE TEMPERATURE

ALEXA CAN ONLY CHANGE THE TEMPERATURE BETWEEN 10° & 32°.

"Alexa, set temperature to 27 degrees."

"Alexa, make it warmer in there." - Increases the temperature by 3°

"Alexa, make it cooler in there." - Decreases the temperature by 3°

CHANGING THE FLAME EFFECT

"Alexa, set animation to....."



COMMANDS FOR GOOGLE HOME

When using Google Home to control your appliance settings remember to substitute the words 'the fire' for whatever you have named your appliance. Please note that the Google Home app cannot control the heater in the appliance.

TURNING THE APPLIANCE ON AND OFF

"Ok Google, turn on the fire."/ "Ok Google, turn off the fire."

CHANGING THE FLAME EFFECT

"Ok Google, change the animation to on the fire."



RETRO-FITTING THE REMOTE CONTROL

In order to retro-fit your remote on older models, please ensure you follow these steps **BEFORE** you attempt to use the remote control system.

1

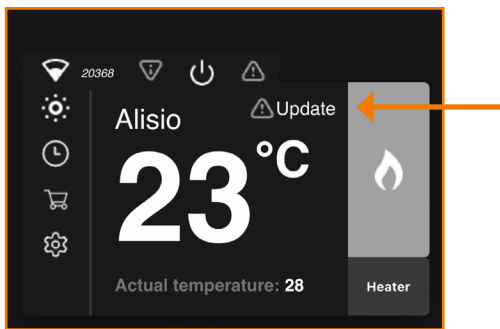

To begin the retro-fit of the remote control, press the 'update' icon on the e-smart cloud app home screen.

2



Once the fire has updated, select the settings icon on the home screen.

3

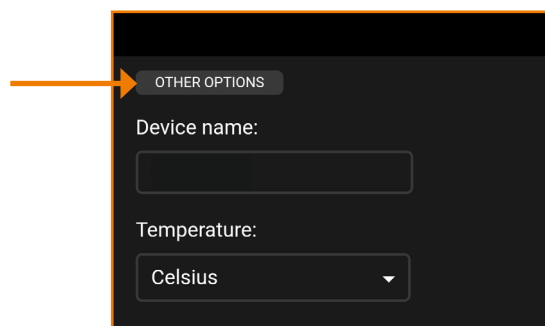

Once the settings panel is open, click 'other options'.

4

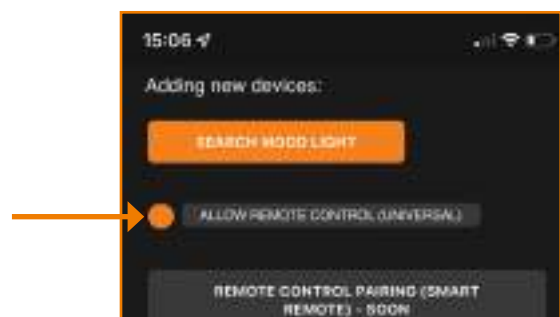

Scroll down to the section that states 'allow remote control (universal)'. Ensure this is highlighted and press save.

5

Press save. You will then hear an audible beep to notify you of the pairing.

6

Turn your fire OFF, then back ON. Your remote will now be paired and ready to use.

WARRANTY

Aura Fires 2-year warranty – 1 year parts & labour. Recieve an additional year by registering your Aura fireplace online - www.aurafires.co.uk

To receive your Extended Warranty your product must be registered with within one month of the purchase date or installation date. The commencement date for the warranty period is the date of purchase.

During the registration process, the details of the Retailer / Supplier from whom you purchased your product will be required for your Extended Warranty to be activated. Any product purchased not registered within the stated time will carry a standard 12-month warranty, or minimum statutory warranty for your country. The Extended Warranty for your Aura product extends the standard 12-month warranty by a further 12 months to a total warranty period of 2 years.

You can register your purchase via the registration card supplied, or by registering your product online, and choosing to opt-in we can keep you up-to-date with useful technical updates or the latest product information that will help you gain even more enjoyment from your new Aura product.

It is a condition of the Extended Warranty that the installation complies with relevant Building Regulations and the rules in force, and is carried out in accordance with the Installation Instructions.

This Warranty can be transferred in the event that the Customer sells the appliance within the Warranty period. The Customer must inform Aura Fires in writing of the sale within 14 days of the resale. Failure to notify Aura Fires within 14 days will result in the Warranty becoming invalid. Please pass on the dated sales receipt as a proof of purchase to the new owner.

The product must be adequately serviced and maintained. This may include, but is not limited to, cleaning the filters and maintaining the silks. Please see your Aura Fires Installation and Operating Instructions for further information on how to service and maintain your Electric appliance.

During your extended warranty period, only genuine Aura Fires spare parts must be used in the servicing and maintenance of your Stove or Fireplace, these spare parts can be ordered from **www.aurafires.co.uk** in the UK, or from an Expert Supplier directly.

Consumable items such as glass, screens, bulbs, LED boards, filters and batteries which are either subject to normal wear and tear or parts that require replacement in connection with normal maintenance are not covered either by the original or the Extended Warranty.

Should you experience problems with your Aura product, any claim must be submitted first to the Retailer / Supplier from whom the product was purchased. Your Retailer / Supplier will either be able to offer immediate assistance, or having visited you, make contact with Aura Fires on your behalf.

For a Service call to be arranged Aura Fires will require proof of registration. Any Warranty claim without the required information will be referred back to your Retailer / Supplier from whom you purchased it.

To progress any Warranty claims for damaged appliance/parts, paint or any visual defects, photographic or video evidence must be supplied. Failure to provide photographic evidence may result in the claim being delayed or refused.

A service call will only be logged once the retailer or installer has inspected the appliance and verified that there is a manufacturing fault. Any visit by a Aura Fires Engineer or approved third party will incur a service charge if, the engineer inspects the appliance and concludes there is no manufacturing fault.

NOTES

A series of horizontal dotted lines for writing notes.

